

Smart-UPS™ VT

10–40 kVA 380/400/415 V

Single and Parallel Installation

With Batteries
11/2016



Legal Information

The Schneider Electric brand and any registered trademarks of Schneider Electric Industries SAS referred to in this guide are the sole property of Schneider Electric SA and its subsidiaries. They may not be used for any purpose without the owner's permission, given in writing. This guide and its content are protected, within the meaning of the French intellectual property code (Code de la propriété intellectuelle français, referred to hereafter as "the Code"), under the laws of copyright covering texts, drawings and models, as well as by trademark law. You agree not to reproduce, other than for your own personal, noncommercial use as defined in the Code, all or part of this guide on any medium whatsoever without Schneider Electric's permission, given in writing. You also agree not to establish any hypertext links to this guide or its content. Schneider Electric does not grant any right or license for the personal and noncommercial use of the guide or its content, except for a non-exclusive license to consult it on an "as is" basis, at your own risk. All other rights are reserved.

Electrical equipment should be installed, operated, serviced, and maintained only by qualified personnel. No responsibility is assumed by Schneider Electric for any consequences arising out of the use of this material.

As standards, specifications, and designs change from time to time, please ask for confirmation of the information given in this publication.

Table of Contents

Important Safety Instructions — SAVE THESE INSTRUCTIONS	5
Safety Precautions	6
Specifications	11
AC Input Specifications	11
AC Bypass Specifications	11
AC Output Specifications	12
Battery Specifications	12
Fuses and Breakers.....	12
Single Utility/Mains System.....	13
Dual Utility/Mains System	13
Parallel System.....	14
Recommended Cable Sizes	16
Recommended Lug Size and Torque Value.....	16
Mechanical Assembly	17
Clearance	17
Level the Cabinets.....	17
Remove the Front Panel	18
Floor Anchoring	19
Connect Floor Anchoring Brackets to the UPS and Modular Battery Cabinet for Stability	19
Remove the Modular Batteries from the UPS Cabinet(s)	21
Install the Baying Kit for Interconnection of Cabinets and Seismic Anchoring (Option).....	23
Install Modular Battery Cabinets (Option)	26
Remove the Cable Landing Cover and Bottom Plates.....	26
Connect Battery Power in Installations with Busbars.....	27
Isolator Installation Principle	27
Install Busbars in 523 mm (20.59 in) UPS System with the UPS Placed to the Left.....	28
Install Busbars in 523 mm (20.59 in) UPS System with the UPS Placed to the Right.....	29
Install Busbars in 352 mm (13.85 in) UPS System with the UPS Placed to the Right.....	30
Install Busbars in 352 mm (13.85 in) UPS System with the UPS Placed to the Left.....	32
Connect Battery Power in Installations with Cables	33
Connect Battery Cables Between the UPS and the Modular Battery Cabinet	33
Connect Battery Cables Between Two Modular Battery Cabinets.....	35
Connect the Power Cables to the UPS.....	37
Single Mains without MBP	37
Dual Mains without MBP	38
Single Mains with MBP	39
Prepare for Cables	40
Bottom Cable Entry.....	40
Connect the Input, Bypass, and Output Cables	41

- Connect the Communication Cables 44
 - Prepare for Communication Cables 44
 - Overview of the Pin Connections 45
 - J106 45
 - Connect EPO in Single Systems 45
 - Connect EPO in Parallel Systems 46
 - Connect Communication Cables between UPS and Modular Battery Cabinet 48
 - Connect Schneider Electric Communication Options 49
 - Connect Communication Cables in Parallel System 50
- Final Mechanical Installation 56
 - Install Batteries and Connect Battery Securing Brackets 56
 - Reinstall the Top Plate and the Front Panel 57

Important Safety Instructions — SAVE THESE INSTRUCTIONS

Read these instructions carefully and look at the equipment to become familiar with it before trying to install, operate, service or maintain it. The following safety messages may appear throughout this manual or on the equipment to warn of potential hazards or to call attention to information that clarifies or simplifies a procedure.



The addition of this symbol to a “Danger” or “Warning” safety message indicates that an electrical hazard exists which will result in personal injury if the instructions are not followed.



This is the safety alert symbol. It is used to alert you to potential personal injury hazards. Obey all safety messages with this symbol to avoid possible injury or death.

DANGER

DANGER indicates a hazardous situation which, if not avoided, **will result in death or serious injury**.

Failure to follow these instructions will result in death or serious injury.

WARNING

WARNING indicates a hazardous situation which, if not avoided, **could result in death or serious injury**.

Failure to follow these instructions can result in death, serious injury, or equipment damage.

CAUTION

CAUTION indicates a hazardous situation which, if not avoided, **could result in minor or moderate injury**.

Failure to follow these instructions can result in injury or equipment damage.

NOTICE

NOTICE is used to address practices not related to physical injury. The safety alert symbol shall not be used with this type of safety message.

Failure to follow these instructions can result in equipment damage.

Please Note

Electrical equipment should only be installed, operated, serviced, and maintained by qualified personnel. No responsibility is assumed by Schneider Electric for any consequences arising out of the use of this material.

A qualified person is one who has skills and knowledge related to the construction, installation, and operation of electrical equipment and has received safety training to recognize and avoid the hazards involved.

Safety Precautions

⚠ DANGER

HAZARD OF ELECTRIC SHOCK, EXPLOSION, OR ARC FLASH

All safety instructions in this document must be read, understood and followed.

Failure to follow these instructions will result in death or serious injury.

⚠ DANGER

HAZARD OF ELECTRIC SHOCK, EXPLOSION, OR ARC FLASH

Read all instructions in the Installation Manual before installing or working on this UPS system.

Failure to follow these instructions will result in death or serious injury.

⚠ DANGER

HAZARD OF ELECTRIC SHOCK, EXPLOSION, OR ARC FLASH

Do not install the UPS system until all construction work has been completed and the installation room has been cleaned.

Failure to follow these instructions will result in death or serious injury.

⚠ DANGER

HAZARD OF ELECTRIC SHOCK, EXPLOSION, OR ARC FLASH

- The product must be installed according to the specifications and requirements as defined by Schneider Electric. It concerns in particular the external and internal protections (upstream breakers, battery breakers, cabling, etc.) and environmental requirements. No responsibility is assumed by Schneider Electric if these requirements are not respected.
- After the UPS system has been electrically wired, do not start up the system. Start-up must only be performed by Schneider Electric.

Failure to follow these instructions will result in death or serious injury.

⚠ DANGER

HAZARD OF ELECTRIC SHOCK, EXPLOSION, OR ARC FLASH

The UPS system must be installed according to local and national regulations. Install the UPS according to:

- IEC 60364 (including 60364–4–41 - protection against electric shock, 60364–4–42 - protection against thermal effect, and 60364–4–43 - protection against overcurrent), **or**
- NEC NFPA 70, **or**
- Canadian Electrical Code (C22.1, Part 1)

depending on which one of the standards apply in your local area.

Failure to follow these instructions will result in death or serious injury.

⚠ DANGER

HAZARD OF ELECTRIC SHOCK, EXPLOSION, OR ARC FLASH

- Install the UPS system in a temperature controlled indoor environment free of conductive contaminants and humidity.
- Install the UPS system on a non-flammable, level and solid surface (e.g. concrete) that can support the weight of the system.

Failure to follow these instructions will result in death or serious injury.

⚠ DANGER

HAZARD OF ELECTRIC SHOCK, EXPLOSION, OR ARC FLASH

The UPS is not designed for and must therefore not be installed in the following unusual operating environments:

- Damaging fumes
- Explosive mixtures of dust or gases, corrosive gases, or conductive or radiant heat from other sources
- Moisture, abrasive dust, steam or in an excessively damp environment
- Fungus, insects, vermin
- Salt-laden air or contaminated cooling refrigerant
- Pollution degree higher than 2 according to IEC 60664-1
- Exposure to abnormal vibrations, shocks, and tilting
- Exposure to direct sunlight, heat sources, or strong electromagnetic fields

Failure to follow these instructions will result in death or serious injury.

⚠ DANGER

HAZARD OF ELECTRIC SHOCK, EXPLOSION, OR ARC FLASH

Do not drill or cut holes for cables or conduits with the gland plates installed and do not drill or cut holes in close proximity to the UPS.

Failure to follow these instructions will result in death or serious injury.

⚠ WARNING

HAZARD OF ARC FLASH

Do not make mechanical changes to the product (including removal of cabinet parts or drilling/cutting of holes) that are not described in the Installation Manual.

Failure to follow these instructions can result in death, serious injury, or equipment damage.

NOTICE

RISK OF OVERHEATING

Respect the space requirements around the UPS system and do not cover the product's ventilation openings when the UPS system is in operation.

Failure to follow these instructions can result in equipment damage.

NOTICE

RISK OF EQUIPMENT DAMAGE

Do not connect the UPS output to regenerative load systems including photovoltaic systems and speed drives.

Failure to follow these instructions can result in equipment damage.

Electrical Safety

⚠ DANGER

HAZARD OF ELECTRIC SHOCK, EXPLOSION OR ARC FLASH

- Electrical equipment must be installed, operated, serviced, and maintained only by qualified personnel.
- Apply appropriate personal protective equipment (PPE) and follow safe electrical work practices.
- Turn off all power supplying the UPS system before working on or inside the equipment.
- Before working on the UPS system, check for hazardous voltage between all terminals including the protective earth.
- The UPS contains an internal energy source. Hazardous voltage can be present even when disconnected from the utility/mains supply. Before installing or servicing the UPS system, ensure that the units are OFF and that utility/mains and batteries are disconnected. Wait five minutes before opening the UPS to allow the capacitors to discharge.
- A disconnection device (e.g. disconnection circuit breaker or switch) must be installed to enable isolation of the system from upstream power sources in accordance with local regulations. This disconnection device must be easily accessible and visible.
- The UPS must be properly earthed/grounded and due to a high leakage current, the earthing/grounding conductor must be connected first.

Failure to follow these instructions will result in death or serious injury.

⚠ DANGER

HAZARD OF ELECTRIC SHOCK, EXPLOSION, OR ARC FLASH

In systems where backfeed protection is not part of the standard design, an automatic isolation device (backfeed protection option or other device meeting the requirements of IEC/EN 62040–1 or UL 1778 4th Edition – depending on which of the two standards apply to your local area) must be installed to prevent hazardous voltage or energy at the input terminals of the isolation device. The device must open within 15 seconds after the upstream power supply fails and must be rated according to the specifications.

Failure to follow these instructions will result in death or serious injury.

When the UPS input is connected through external isolators that, when opened, isolate the neutral or when the automatic backfeed isolation is provided external to the equipment or is connected to an IT power distribution system, a label must be fitted at the UPS input terminals, and on all primary power isolators installed remote from the UPS area and on external access points between such isolators and the UPS, by the user, displaying the following text (or equivalent in a language which is acceptable in the country in which the UPS system is installed):

⚠ DANGER

HAZARD OF ELECTRIC SHOCK, EXPLOSION, OR ARC FLASH

Risk of Voltage Backfeed. Before working on this circuit: Isolate the UPS and check for hazardous voltage between all terminals including the protective earth.

Failure to follow these instructions will result in death or serious injury.

Battery Safety

⚠ DANGER

HAZARD OF ELECTRIC SHOCK, EXPLOSION, OR ARC FLASH

- Battery circuit breakers must be installed according to the specifications and requirements as defined by Schneider Electric.
- Servicing of batteries must only be performed or supervised by qualified personnel knowledgeable of batteries and the required precautions. Keep unqualified personnel away from batteries.
- Disconnect charging source prior to connecting or disconnecting battery terminals.
- Do not dispose of batteries in a fire as they can explode.
- Do not open, alter, or mutilate batteries. Released electrolyte is harmful to the skin and eyes. It may be toxic.

Failure to follow these instructions will result in death or serious injury.

⚠ DANGER

HAZARD OF ELECTRIC SHOCK, EXPLOSION, OR ARC FLASH

Batteries can present a risk of electric shock and high short-circuit current. The following precautions must be observed when working on batteries

- Remove watches, rings, or other metal objects.
- Use tools with insulated handles.
- Wear protective glasses, gloves and boots.
- Do not lay tools or metal parts on top of batteries.
- Disconnect the charging source prior to connecting or disconnecting battery terminals.
- Determine if the battery is inadvertently grounded. If inadvertently grounded, remove source from ground. Contact with any part of a grounded battery can result in electric shock. The likelihood of such shock can be reduced if such grounds are removed during installation and maintenance (applicable to equipment and remote battery supplies not having a grounded supply circuit).

Failure to follow these instructions will result in death or serious injury.

⚠ DANGER

HAZARD OF ELECTRIC SHOCK, EXPLOSION, OR ARC FLASH

When replacing batteries, always replace with the same type and number of batteries or battery packs.

Failure to follow these instructions will result in death or serious injury.

NOTICE

RISK OF EQUIPMENT DAMAGE

- Wait until the system is ready to be powered up before installing batteries in the system. The time duration from battery installation until the UPS system is powered up must not exceed 72 hours or 3 days.
- Batteries must not be stored more than six months due to the requirement of recharging. If the UPS system remains de-energized for a long period, Schneider Electric recommends that you energize the UPS system for a period of 24 hours at least once every month. This charges the batteries, thus avoiding irreversible damage.

Failure to follow these instructions can result in equipment damage.

Product Specific Safety Information

NOTE: The system is designed for connection to an IT power distribution system.

NOTE: The parallel cables must be run by the electrician but not attached. The field service engineer from Schneider Electric will install the parallel communication box and attach all cables to the UPS units.

NOTE: Battery and utility power must not be connected until all other wiring has been completed.

Specifications

⚠ DANGER

HAZARD OF ELECTRIC SHOCK, EXPLOSION OR ARC FLASH

The UPS must be supplied from a 380/220 V, 400/230 V or 415/240 V L1, L2, L3, N, PE, 50 Hz.

Failure to follow these instructions will result in death or serious injury.

AC Input Specifications

3:3 380/400/415 V

kVA	10			15			20			30			40		
V	380	400	415	380	400	415	380	400	415	380	400	415	380	400	415
Connection type	3PH + N + PE														
Voltage range (V)	304-477 at 100% load 200-477 at < 50% load														
Input frequency (Hz)	40-70														
THDI	< 5% at full load														
Nominal input current (A)	13.0	12.3	11.9	19.4	18.5	17.8	26.0	24.7	23.8	38.6	36.7	35.3	51.7	49.1	47.3
Maximum input current (A)	14.3	13.5	13.1	21.4	20.3	19.6	28.6	27.2	26.2	42.5	40.3	38.9	56.8	54.0	52.1
Input current limitation (A)	18			26.7			35.5			53			70.6		
Input power factor correction	0.98 at load > 50%														
Maximum input short circuit withstand (kA) Icc	Rated conditional short circuit current Icc: 30 kA Rated peak withstand current Ipk: Icc x 1.7 Device: Refer to <i>Required Upstream Fuse and Breaker Sizes in Single System, page 14.</i>														

AC Bypass Specifications

NOTE: The UPS is capable of running with a bypass input frequency of 50 Hz or 60 Hz. The frequency setting can be configured via the UPS display (**Setup > Settings > System > Frequency**).

3:3 380/400/415 V

kVA	10			15			20			30			40		
V	380	400	415	380	400	415	380	400	415	380	400	415	380	400	415
Connection type	3PH + N + PE														
Voltage range (V)	± 10%														
Input frequency (Hz)	50 ± 10 or 60 ± 10														
Nominal input current (A)	15.2	14.4	13.9	22.8	21.7	20.9	30.4	28.9	27.8	45.6	43.3	41.7	60.8	57.7	55.6
Maximum input short circuit withstand (kA) Icc	Rated conditional short circuit current Icc: 30 kA Rated peak withstand current Ipk: Icc x 1.7 Device: Refer to <i>Required Upstream Fuse and Breaker Sizes in Single System, page 14.</i>														

AC Output Specifications

3:3 380/400/415 V

kVA	10			15			20			30			40		
V	380	400	415	380	400	415	380	400	415	380	400	415	380	400	415
Connection type	3PH + N + PE														
Output capacity	150% for 1 minute (normal operation) 125% for 10 minutes (normal operation) 150% for 1 minute (battery operation) 110% continuous (bypass operation) 800% for 500 ms (bypass operation)														
Nominal output current (A)	15.2	14.4	13.9	22.8	21.7	20.9	30.4	28.9	27.8	45.6	43.3	41.7	60.8	57.7	55.6
Output frequency (sync to mains)	47-53 Hz for 50 Hz nominal														
Slew rate (Hz/Sec)	0.25-1														
THDU	< 1.5% linear < 3.5% non-linear														
Output power factor	0.8														
Dynamic load response	+/- 5%														
Output voltage regulation	+/- 1%														

Battery Specifications

Type	VRLA
Nominal voltage (VDC)	+/- 192
Float voltage (VDC)	+/- 219
End of discharge voltage (VDC)	+/- 154
Battery current (at full load)	87.9 A at +/- 192 V
Maximum current (at end of discharge)	110.1 A at + 154 V
Maximum charging power	10 kVA: 1600 W 15 kVA: 2400 W 20 kVA: 3200 W 30 kVA: 3200 W 40 kVA: 3200 W
Maximum charging current	10 kVA: 4.2 A 15 kVA: 6.3 A 20 kVA: 8.4 A 30 kVA: 8.4 A 40 kVA: 8.4 A
Typical recharge time	5 hours
End voltage	1.6-1.75 V/cell (automatic, depending on load)

Fuses and Breakers

NOTE: For installations with a Schneider Electric maintenance bypass panel, refer to the installation manual provided with the maintenance bypass panel for wiring diagrams.

Single Utility/Mains System

- Q1: Utility/mains input
- Q2: UPS output
- Q3: Manual bypass
- MBS: Mechanical bypass switch

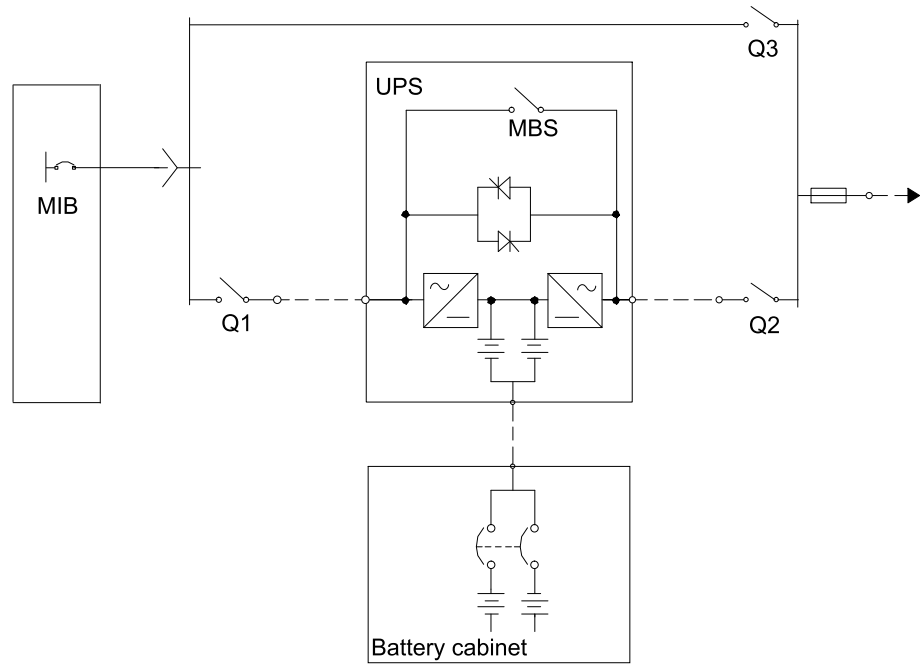

Dual Utility/Mains System

- Q1: Utility/mains input
- Q2: UPS output
- Q3: Manual bypass
- Q5: Static bypass input
- MBS: Mechanical bypass switch

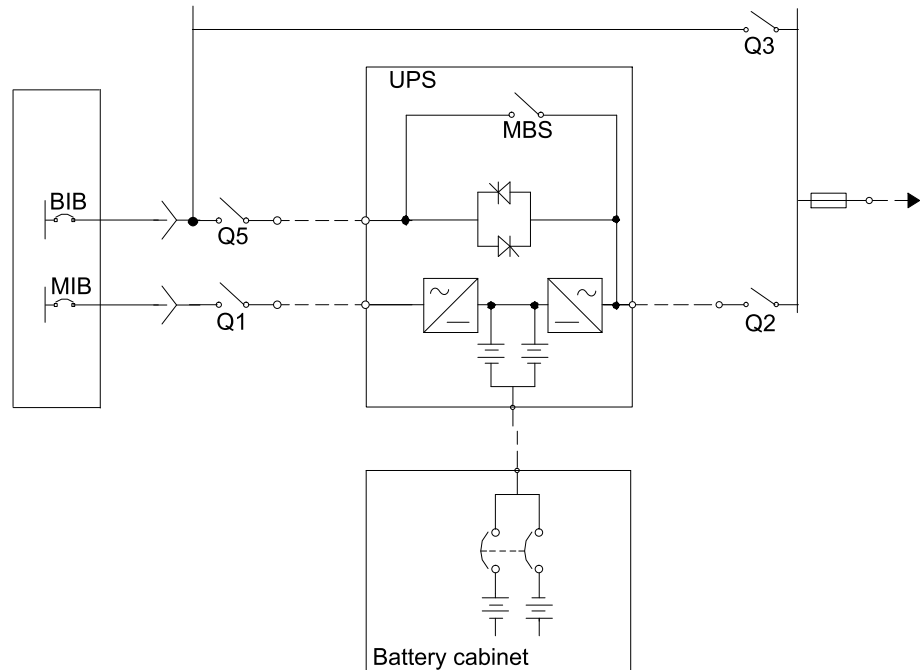

Parallel System

- Q1: Utility/mains input
- Q2: UPS output
- Q3: Manual bypass
- Q4: System output
- Q5: Static bypass input

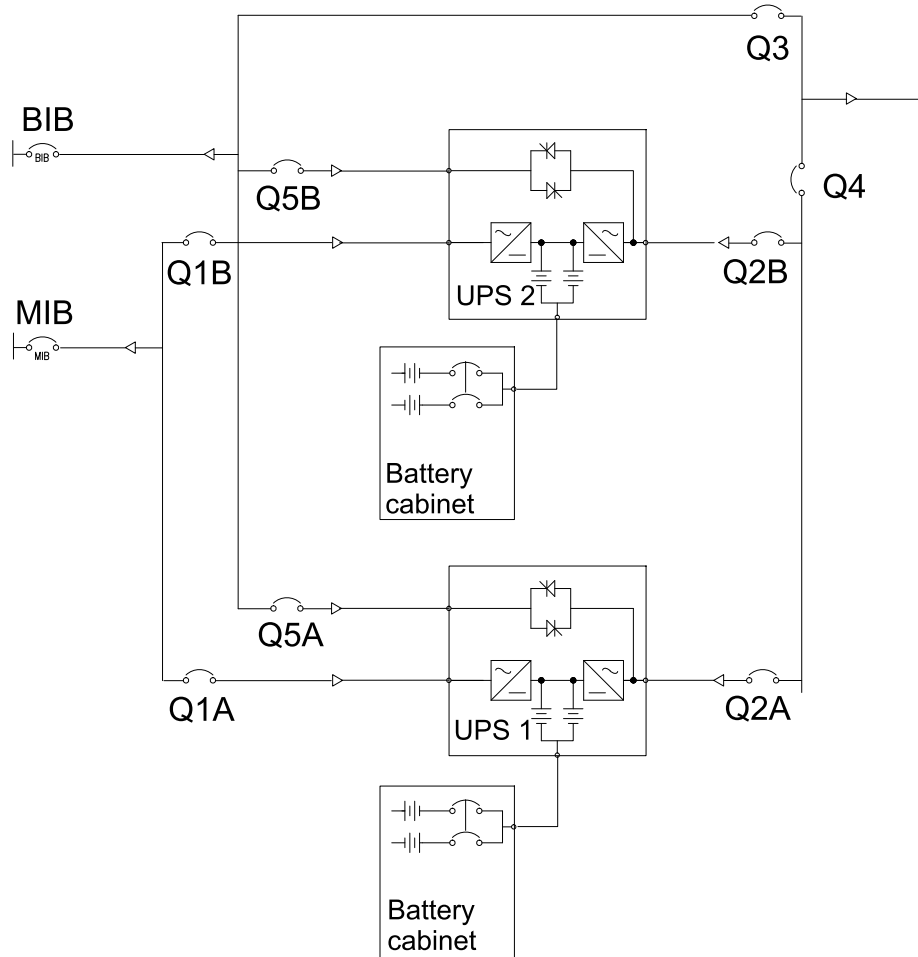

Required Upstream Fuse and Breaker Sizes in Single System

NOTE: The specified upstream breakers below are required to obtain the conditional short circuit current rating, I_{cc} at 30 kA symmetrical rms.

3:3 400 V

	10 kVA	15 kVA
Utility/mains input Q1 (A)	Compact NSX100F-TM-D-16A, or NG125N-C-16A , rating 16 A, or Fuse: 16 A gG/gL	Compact NSX100F-TM-D-25A, or NG125N-C-25A , rating 25 A, or Fuse: 25 A gG/gL
Static bypass input Q5 (A)	Compact NSX100F-TM-D-16A, or NG125N-C-16A , rating 16 A, or Fuse: 16 A gG/gL	Compact NSX100F-TM-D-25A, or NG125N-C-25A , rating 25 A, or Fuse: 25 A gG/gL
UPS output Q2 (A)	16	25
Manual bypass Q3 (A)	16	25
External battery fuse	Fuse fast 125 A 660 VDC 100 kA	

	20 kVA	30 kVA	40 kVA
Utility/mains input Q1 (A)	Compact NSX100F-TM-D-40A, or NG125N-C-40A , rating 40 A, or Fuse: 35 A gG/gL	Compact NSX100F-TM-D-50A, or NG125N-C-50A , rating 50 A, or Fuse: 50 A gG/gL	Compact NSX100F-TM-D-63A, or NG125N-C-63A , rating 63 A, or Fuse: 80 A gG/gL
Static bypass input Q5 (A)	Compact NSX100F-TM-D-40A, or NG125N-C-40A , rating 40 A, or Fuse: 35 A gG/gL	Compact NSX100F-TM-D-50A, or NG125N-C-50A , rating 50 A, or Fuse: 50 A gG/gL	Compact NSX100F-TM-D-63A, or NG125N-C-63A , rating 63 A, or Fuse: 80 A gG/gL
UPS output Q2 (A)	35	50	63
Manual bypass Q3 (A)	35	50	63
External battery fuse	Fuse fast 125 A 660 VDC 100 kA		

Fuse and Breaker Sizes in Parallel System

3:3 400 V – Manual bypass Q3 and System Output Q4 in Parallel Capacity Systems

Units in parallel	10 kVA	15 kVA	20 kVA	30 kVA	40 kVA
2 (A)	35	50	63	100	125
3 (A)	50	80	100	160	200
4 (A)	63	100	200	200	250

3:3 400 V – Manual bypass Q3 and System Output Q4 in Parallel Redundant Systems (n +1)

Units in parallel	10 kVA	15 kVA	20 kVA	30 kVA	40 kVA
2 (A)	16	25	35	50	63
3 (A)	35	50	63	100	125
4 (A)	50	80	100	160	200

Minimum Breaker Settings

3:3 380/400/415 V

		800% overload bypass operation	150% overload normal/battery operation	125% overload normal/battery operation	Continuously
	Duration	500 ms	60 s	10 min	
10 kVA	Utility/mains input	- ¹	-	-	18.0 A
	Static bypass input	121.5 A	-	-	16.7 A
	UPS output	121.5 A	22.8 A	19 A	16.7 A
15 kVA	Utility/mains input	- ¹	-	-	26.7 A
	Static bypass input	182 A	-	-	25.1 A
	UPS output	182 A	34.2 A	25.4 A	25.1 A
20 kVA	Utility/mains input	- ¹	-	-	35.5 A
	Static bypass input	244 A	-	-	33.4 A
	UPS output	244 A	45.6 A	38 A	33.4 A
30 kVA	Utility/mains input	- ¹	-	-	53.0 A
	Static bypass input	364 A	-	-	50.1 A

1. For single utility/mains systems, use the higher value of utility/mains and static bypass.

		800% overload bypass operation	150% overload normal/battery operation	125% overload normal/battery operation	Continuously
	Duration	500 ms	60 s	10 min	
	UPS output	364 A	68.4 A	57 A	50.1 A
40 kVA	Utility/mains input	²	-	-	70.6 A
	Static bypass input	487 A	-	-	66.9 A
	UPS output	487 A	91.2 A	76 A	66.9 A

Recommended Cable Sizes

⚠ DANGER

HAZARD OF ELECTRIC SHOCK, EXPLOSION OR ARC FLASH

At 100% switch mode load, the neutral must be rated for 200% phase current.

Failure to follow these instructions will result in death or serious injury.

NOTE: The recommended cable sizes are based on an environment with an ambient temperature of 30°C.

NOTE: Use Molex lug type or equivalent, and crimp to manufacturer’s specifications.

	Input (mm ²)	Output (mm ²)	Battery (mm ²) 70°C wire	Bypass (mm ²)
10 kVA	2.5	2.5	50	2.5
15 kVA	6	6	50	6
20 kVA	10	10	50	10
30 kVA	16	16	50	16
40 kVA	25	25	50	25

Recommended Lug Size and Torque Value

NOTE: Power terminal lug diameter: 6 mm.
Torque value: 7 Nm.

2. For single utility/mains systems, use the higher value of utility/mains and static bypass.

Mechanical Assembly

Clearance

NOTE: Clearance dimensions are published for airflow and service access only. Consult with the local safety codes and standards for additional requirements in your local area.

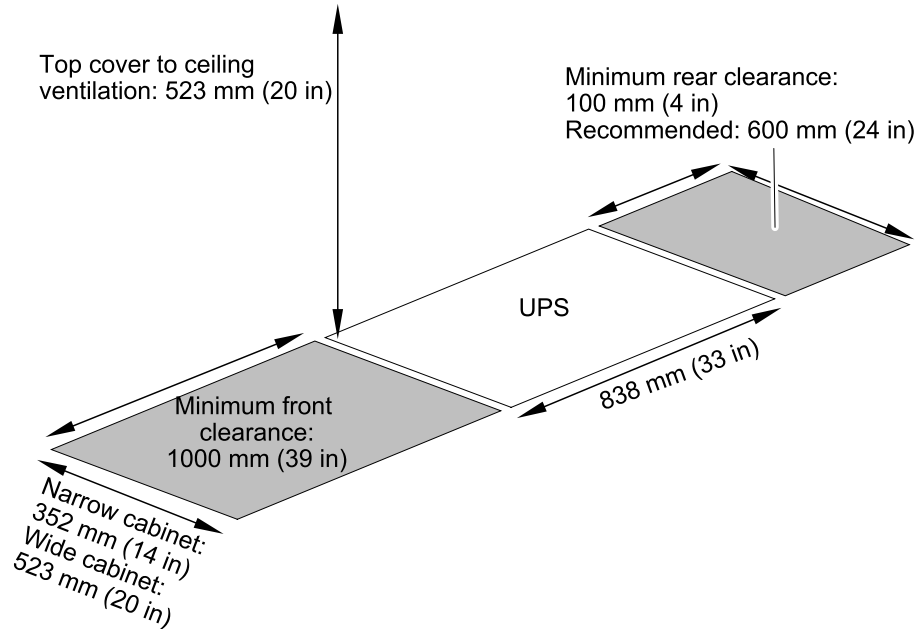

Level the Cabinets

⚠ WARNING

TIP HAZARD

The system must be installed on a level floor. The leveling feet will stabilize the cabinet, but will not compensate for a badly sloped floor.

Failure to follow these instructions can result in death, serious injury, or equipment damage.

1. Use a screwdriver to lower the four leveling feet

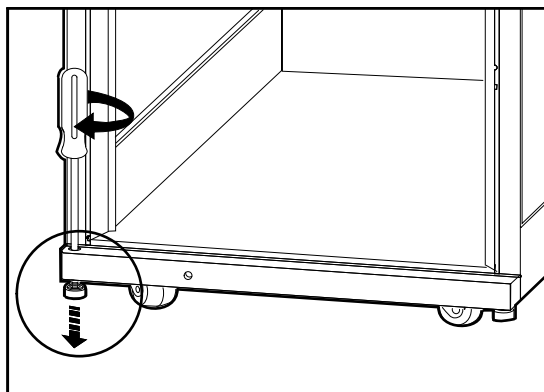

- Use a wrench to adjust the four leveling feet and ensure that the cabinet is level.

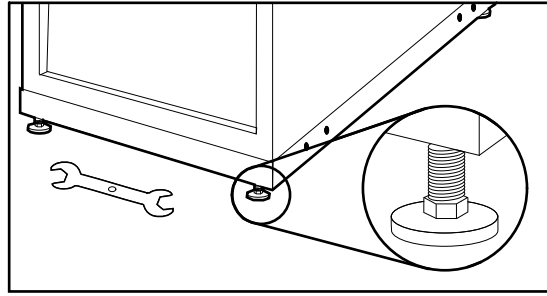

⚠ WARNING

TIP HAZARD

Do not move the cabinet after the leveling feet have been lowered.

Failure to follow these instructions can result in death, serious injury, or equipment damage.

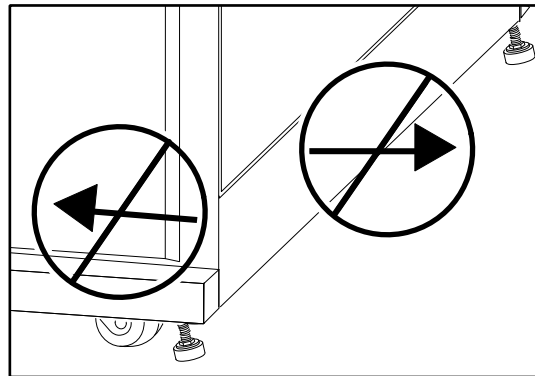

Remove the Front Panel

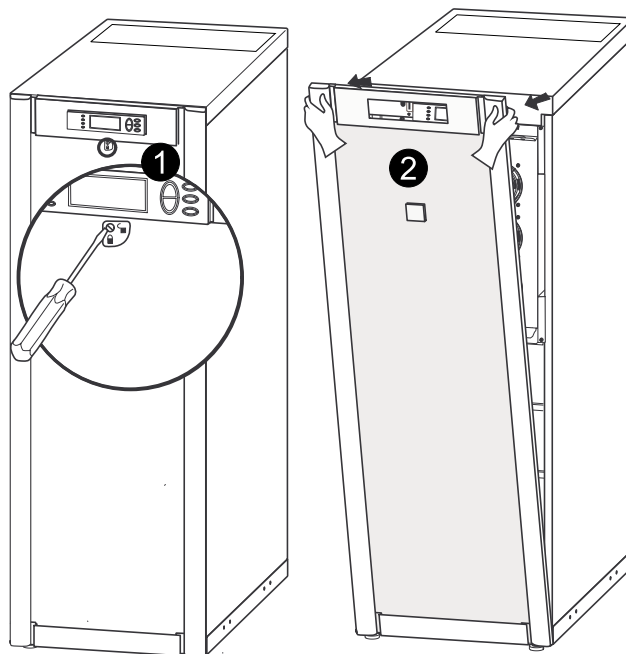

- Turn the screw to the right to the unlocked position.
- Pull the top of the front panel away from the UPS.

3. Lift the front panel free of the two slots at the bottom of the cabinet.
4. Lift the battery compartment cover free of the two slots at the bottom of the cabinet (only applicable in Japanese configurations).

Floor Anchoring

Two floor anchoring options are available depending on the requirements in the installation area:

- For stability: Reuse the L-shaped brackets that held the cabinet to the pallet during shipment for a stand-alone UPS.
- For seismic anchoring: Use a baying kit that includes U-shaped seismic anchoring brackets.

NOTE: Allow for enough working space behind the cabinet for electrical work to be carried out (e.g. if you want to install a modular battery cabinet at a later stage).

NOTE: Hole positions are guidelines only.

Connect Floor Anchoring Brackets to the UPS and Modular Battery Cabinet for Stability

NOTE: Floor anchoring bolts are not provided with the UPS. Purchase the bolts locally (minimum size: M8). Follow the specifications given by the manufacturer of the floor anchoring system when bolting the UPS system to the floor.

NOTE: Recommended minimum number of screws per cabinet for the L-shaped brackets is four; one in each corner. Recommended floor bolt size: M8.

Hole Positions for a Stand-alone UPS Cabinet with L-Shaped Anchoring Brackets – Narrow UPS 352 mm (13.85 in) and Wide UPS 523 mm (20.59 in)

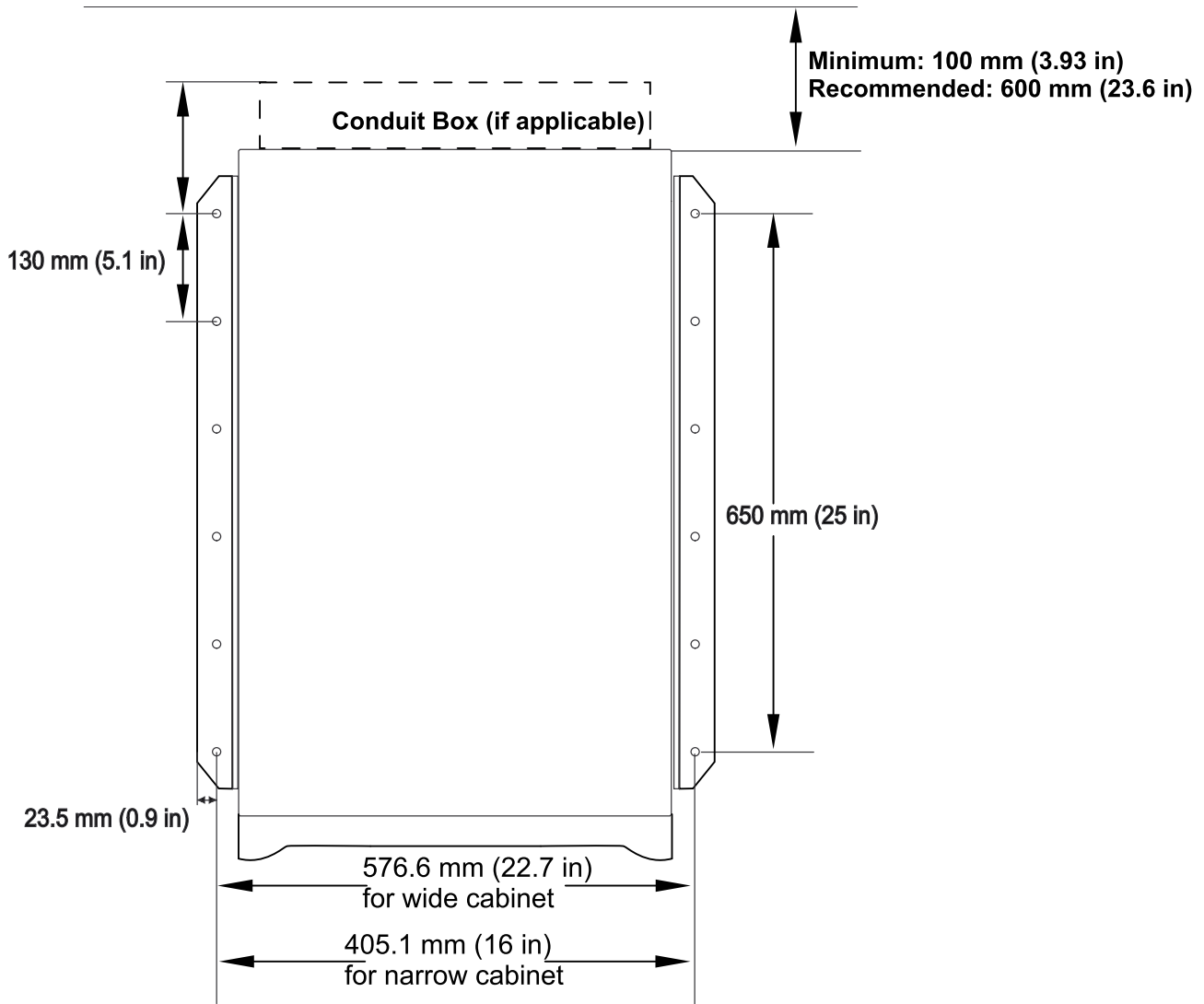

1. Install the L-shaped floor anchoring brackets (reuse the two transport brackets) and secure with the M6 screws and nuts (provided).
2. Drill two to six holes in the floor for each bracket and attach these with bolts.

Side view

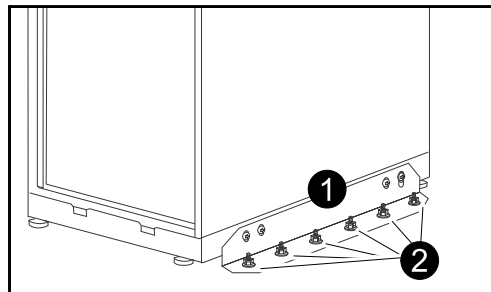

Remove the Modular Batteries from the UPS Cabinet(s)

⚠ DANGER

HAZARD OF ELECTRIC SHOCK, EXPLOSION OR ARC FLASH

- Battery circuit breakers must be installed according to the specifications and requirements as defined by Schneider Electric.
- Servicing of batteries must only be performed or supervised by qualified personnel knowledgeable of batteries and the required precautions. Keep unqualified personnel away from batteries.
- Disconnect charging source prior to connecting or disconnecting battery terminals.
- Do not dispose of batteries in a fire as they can explode.
- Do not open, alter, or mutilate batteries. Released electrolyte is harmful to the skin and eyes. It may be toxic.

Failure to follow these instructions will result in death or serious injury.

⚠ DANGER

HAZARD OF ELECTRIC SHOCK, EXPLOSION, OR ARC FLASH

Batteries can present a risk of electric shock and high short-circuit current. The following precautions must be observed when working on batteries

- Remove watches, rings, or other metal objects.
- Use tools with insulated handles.
- Wear protective glasses, gloves and boots.
- Do not lay tools or metal parts on top of batteries.
- Disconnect the charging source prior to connecting or disconnecting battery terminals.
- Determine if the battery is inadvertently grounded. If inadvertently grounded, remove source from ground. Contact with any part of a grounded battery can result in electric shock. The likelihood of such shock can be reduced if such grounds are removed during installation and maintenance (applicable to equipment and remote battery supplies not having a grounded supply circuit).

Failure to follow these instructions will result in death or serious injury.

⚠ CAUTION

HAZARD OF PERSONAL INJURY

Two persons are required for lifting a modular battery module.

Failure to follow these instructions can result in injury or equipment damage.

NOTE: When you remove modular batteries, start from the highest row and work your way down.

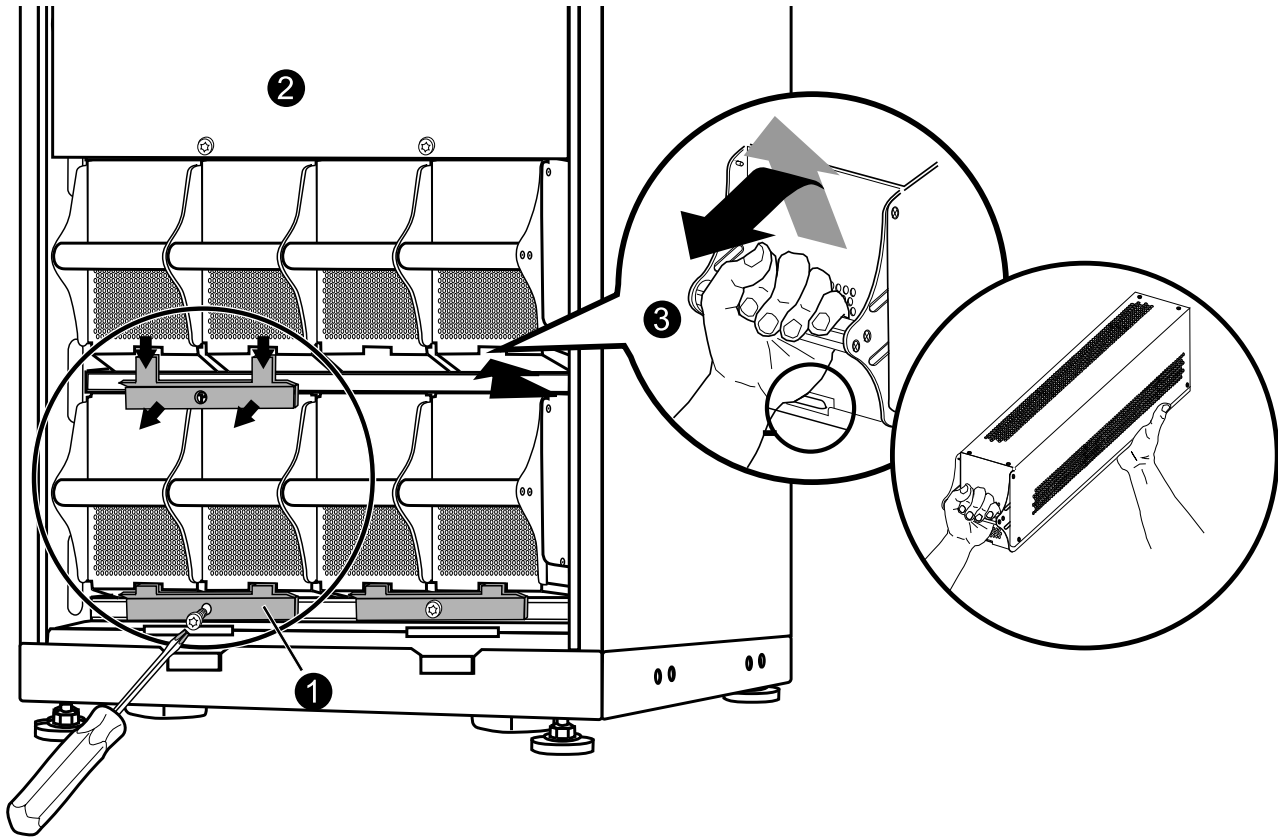

1. Remove all battery securing brackets (used to secure the batteries during transport) by removing the M6 Torx screws.
2. Remove the blind plate.
3. To release the battery from its lock mechanism, gently push the modular battery upwards and then pull it out while supporting the modular battery with your other hand.

Hole Positions for Up to Four UPS Units in Parallel with U-Shaped Anchoring Brackets

NOTE: Recommended minimum number of floor screws for the two configurations below is 10.

Narrow UPS 352 mm (13.85 in)

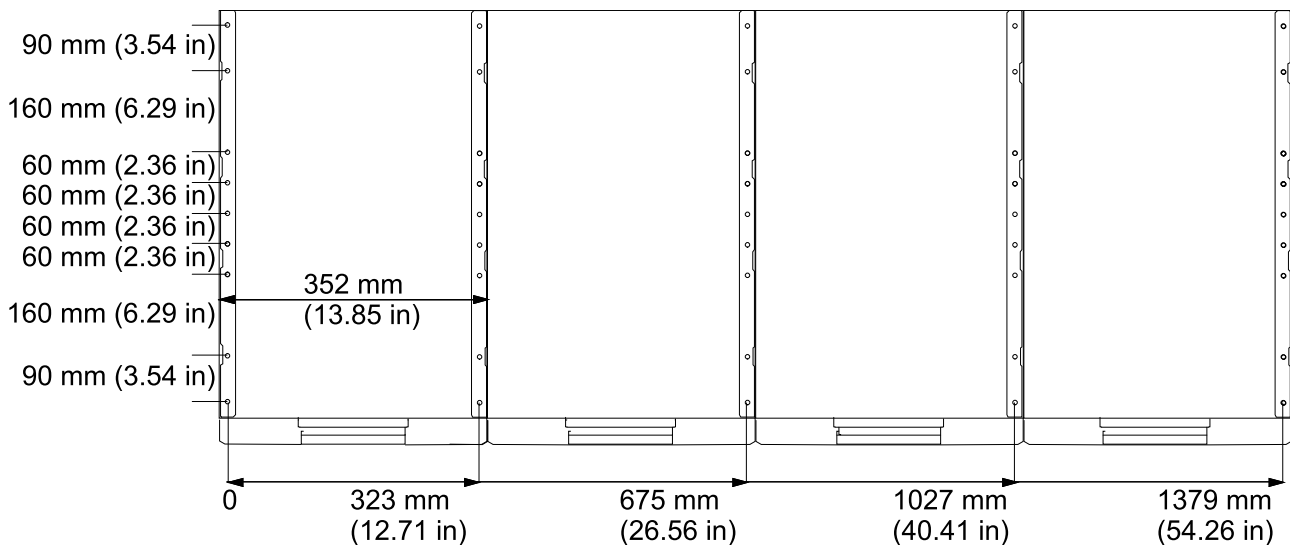

Wide UPS 523 mm (20.59 in)

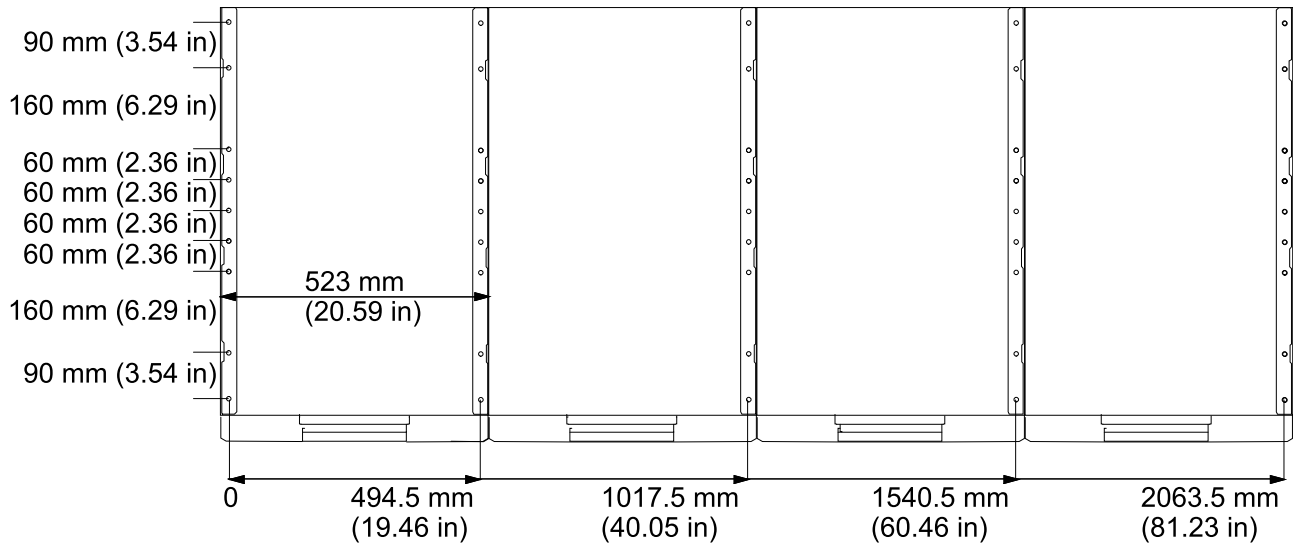

Install the Baying Kit for Interconnection of Cabinets and Seismic Anchoring (Option)

⚠ WARNING
HAZARD OF TILTING
Baying kits are required in seismic areas to prevent the cabinets from tilting during seismic events.
Failure to follow these instructions can result in death, serious injury, or equipment damage.

NOTE: Drill the floor holes according to your configuration as shown in *Hole Positions for Up to Four UPS Units in Parallel with U-Shaped Anchoring Brackets*, page 22.

1. Remove the side panels from the cabinet(s) to get access to the holes in the bottom frame.

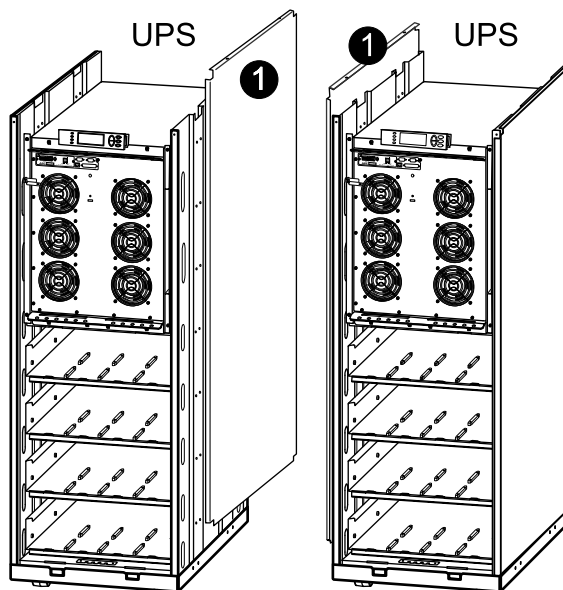

NOTE: Make sure that the cabinets are level so that they can be anchored to each other.

- Position two U-shaped floor anchoring brackets under one cabinet; one on each side.

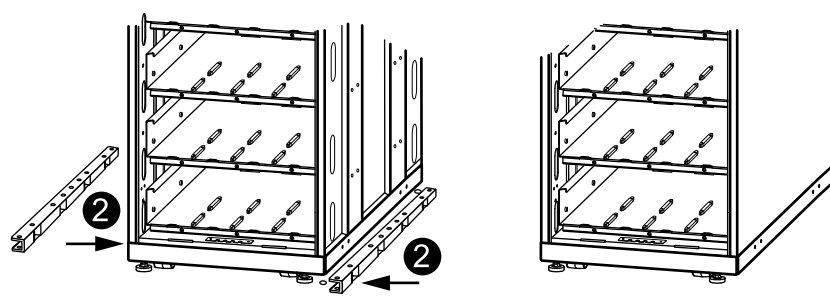

NOTE: The U-shaped anchoring brackets are 1-2 mm higher than the opening below the cabinet to disengage the casters. Therefore, the cabinet must be tilted when placing the U-shaped anchoring brackets under the cabinet.

- On each side of the same cabinet insert a maximum of nine and a minimum of two M8 screws (not provided) through holes in the bottom of the cabinet and through holes in the U-shaped floor anchoring brackets, and into the predrilled floor holes.

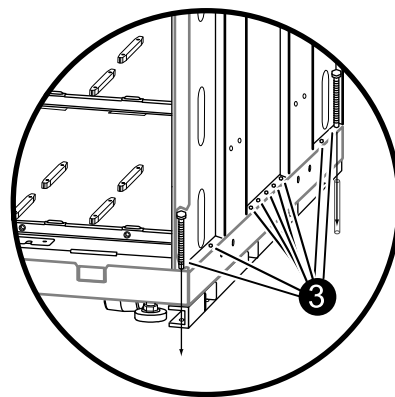

- Fasten the screws.

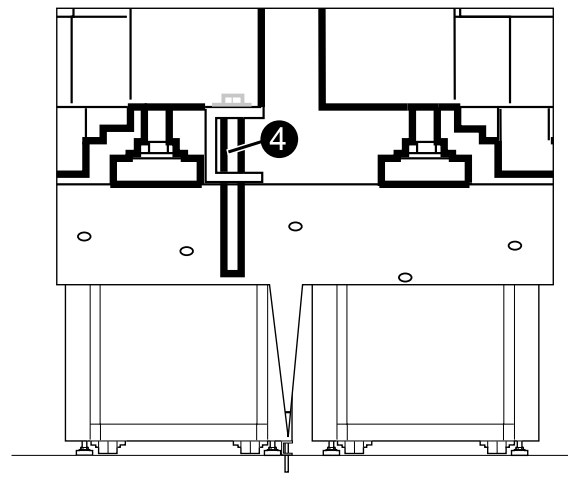

- Move the adjacent cabinet on its casters close to the cabinet with the U-shaped floor anchoring brackets.

▲ CAUTION

RISK OF EQUIPMENT DAMAGE

If the adjacent cabinet is on its leveling feet, use a forklift or pallet jack to move it into position to avoid damaging the leveling feet.

Failure to follow these instructions can result in injury or equipment damage.

- Insert the interconnection plates between the two cabinets. One is positioned toward the front and the other toward the rear. Notice how the “wings” on the interconnection plates rest in slots at the top of the inner panel.

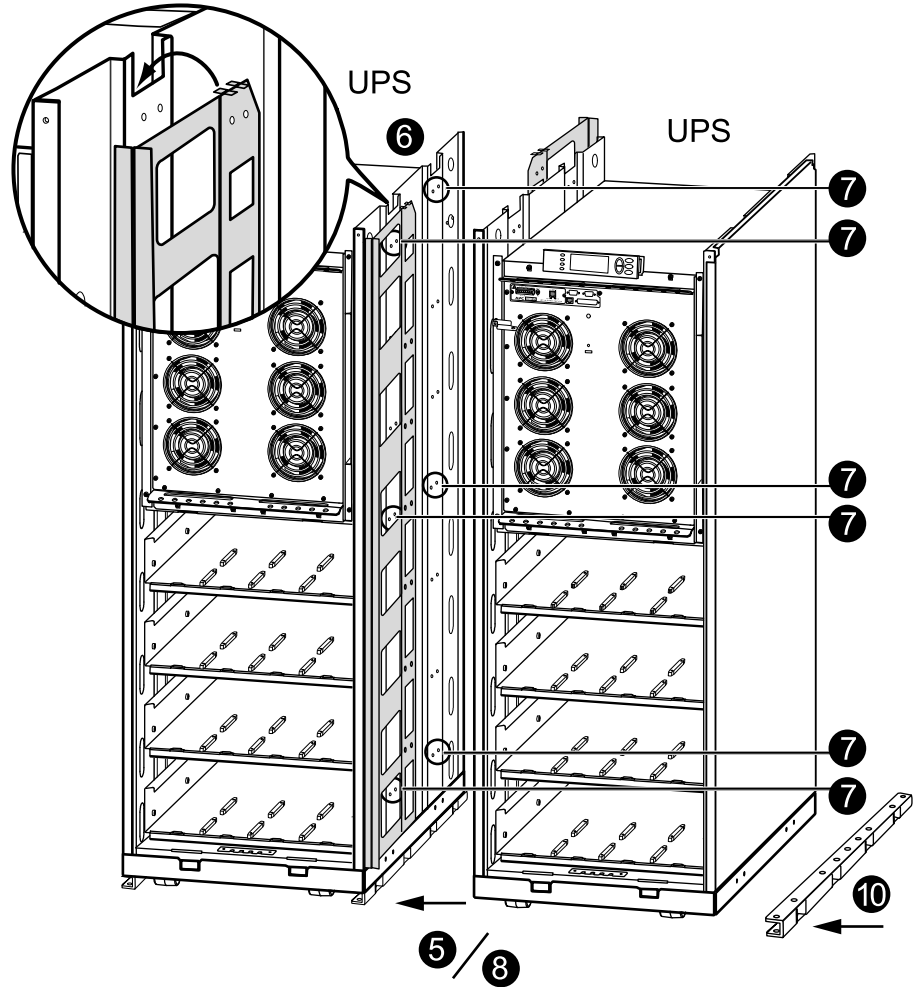

- Align the two cabinets and level the three marked rows of bolt holes in UPS 1 with the holes in UPS 2.
- Push the two cabinets firmly together.
- Bolt the two cabinets together using the six M6x25 mm screws and nuts supplied in the kit; join one hole at the front and one hole at the rear of the cabinets on three levels.

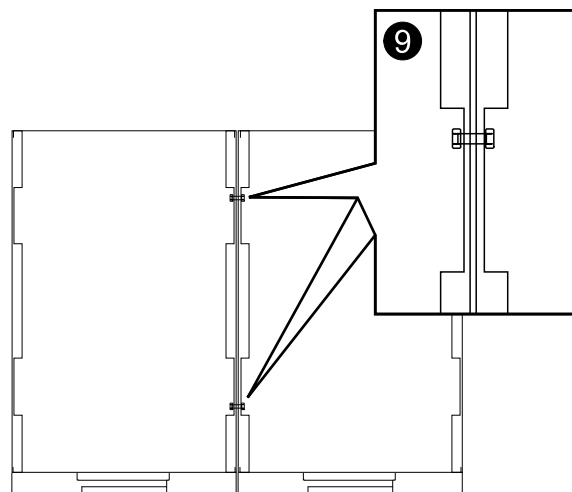

- Position the third U-shaped floor anchoring bracket under the adjacent cabinet (see previous graphics) and insert a minimum of two floor anchoring M8 screws (not provided) through the holes in the bottom of the cabinet and through the holes in the U-shaped floor anchoring bracket, and into the predrilled floor holes, and then fasten the screws.

Install Modular Battery Cabinets (Option)

Remove the Cable Landing Cover and Bottom Plates

⚠ DANGER

HAZARD OF ELECTRIC SHOCK, EXPLOSION OR ARC FLASH

Before carrying out the steps below, the system must be in total power off and the batteries must be removed.

Failure to follow these instructions will result in death or serious injury.

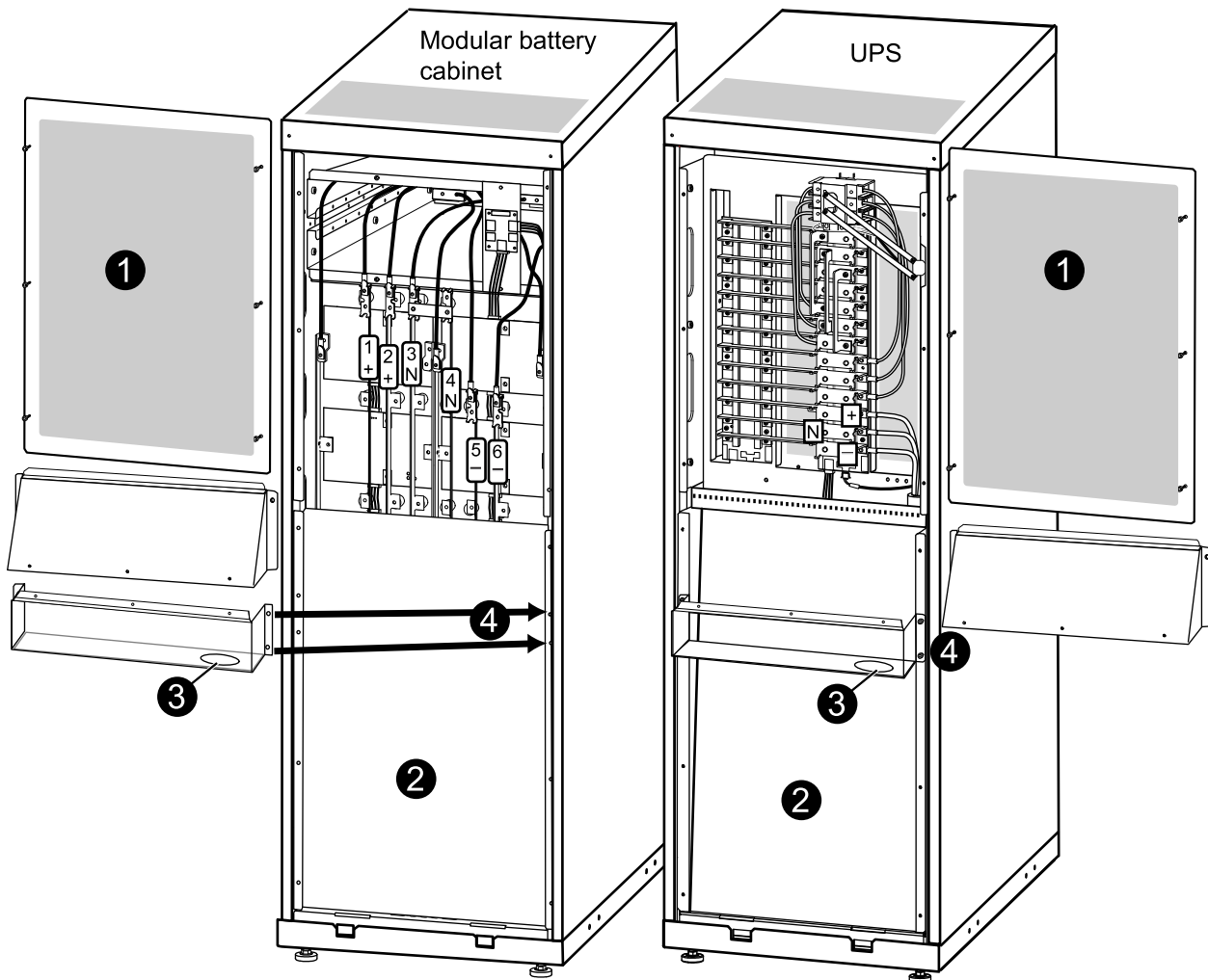

1. Loosen the six M4 screws from the cable landing cover plate on the UPS and the modular battery cabinet(s) and then remove the plates.
2. In installations with busbar connections, remove the screws from the bottom plate on the UPS and the modular battery cabinet(s) and then remove the plates.
3. Punch holes in the bottom of the conduit boxes to fit the size of the conduit pipes.
4. Attach the bottom part of the conduit boxes to the back of the UPS and to the back of the modular battery cabinet with four screws each (if applicable).

Connect Battery Power in Installations with Busbars

⚠ DANGER

HAZARD OF ELECTRIC SHOCK, EXPLOSION OR ARC FLASH

Before carrying out the steps below, the system must be in total power off and the batteries must be removed.

Failure to follow these instructions will result in death or serious injury.

Isolator Installation Principle

The isolators separate the buying kit busbar from the six vertical busbars in each modular battery cabinet, and the (+), N, and (-) busbars in the UPS.

1. Guide the busbar with isolator through the adjacent side panels.

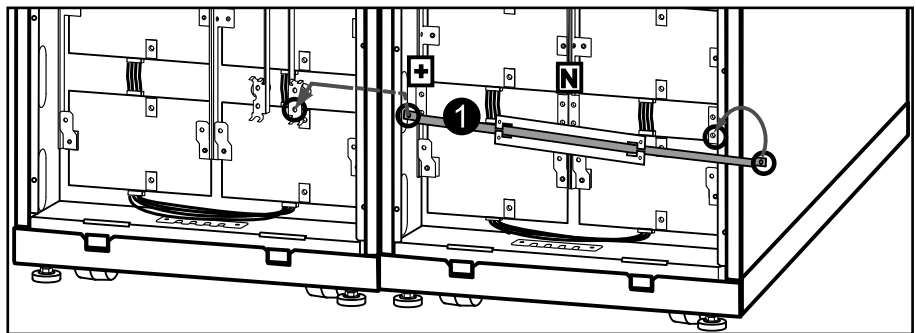

2. Position the isolators across the vertical busbars (N in this example) and then fasten the isolator busbar by using the provided M5 Torx screws.
3. Secure the isolator to its busbar with cable ties.

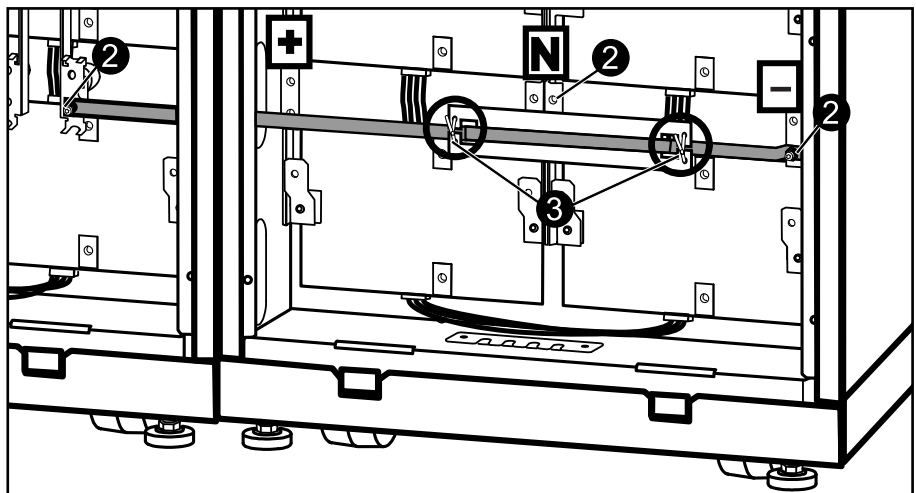

Install Busbars in 523 mm (20.59 in) UPS System with the UPS Placed to the Left

Front view

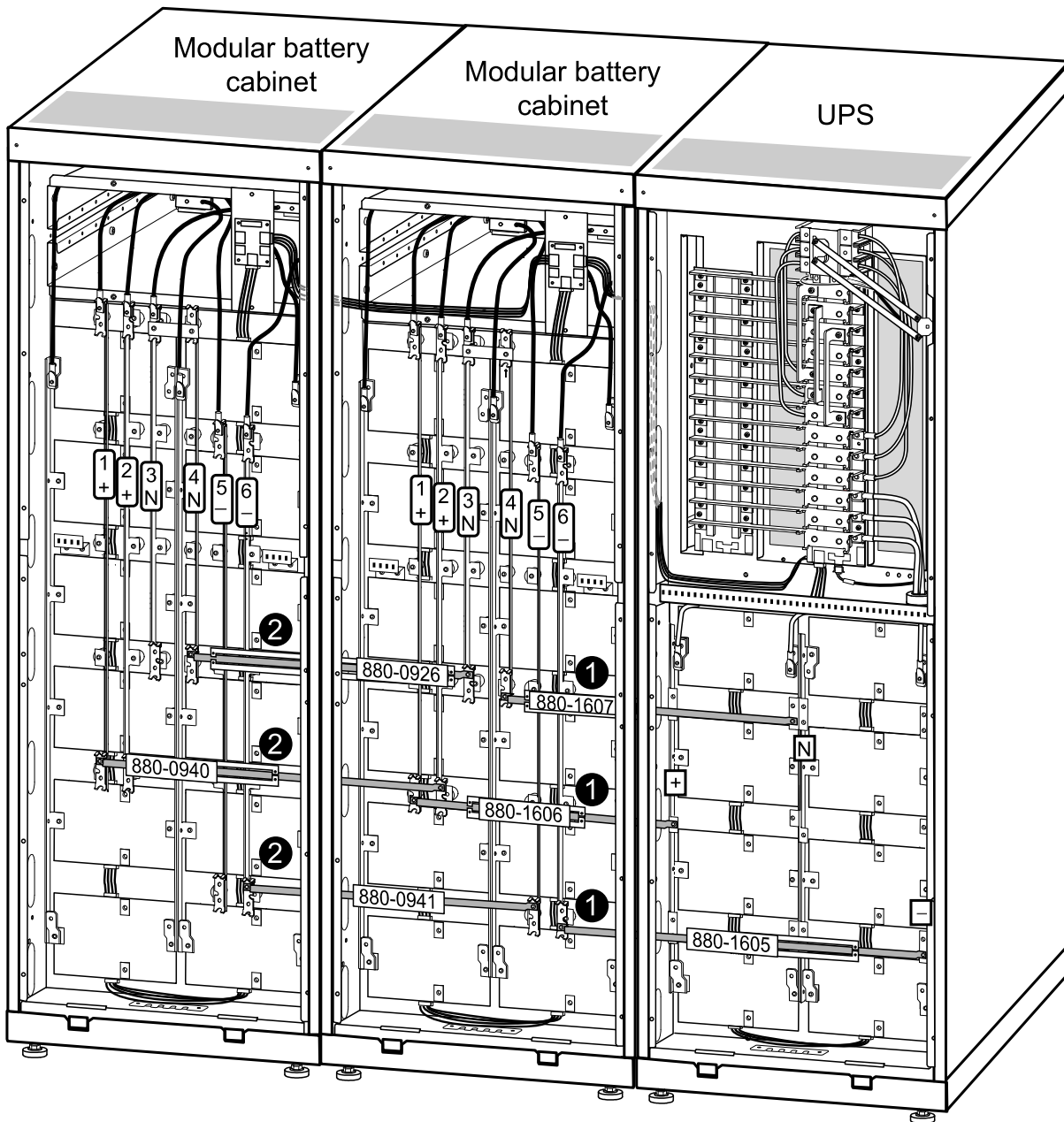

1. Install the following buying kit busbars between the UPS and modular battery cabinet 1:
 - 880-1607 between vertical busbar N on the UPS and busbar 4 on modular battery cabinet 1
 - 880-1606 between vertical busbar (+) on the UPS and busbar 1 on modular battery cabinet 1
 - 880-1605 between busbar (-) on the UPS and busbar 6 on modular battery cabinet 1
2. Install the following buying kit busbars between the two modular battery cabinets:
 - 880-0926 between vertical busbar 3 on modular battery cabinet 1 and busbar 4 on modular battery cabinet 2
 - 880-0940 between vertical busbar 2 on modular battery cabinet 1 and busbar 1 on modular battery cabinet 2
 - 880-0941 between vertical busbar 5 on modular battery cabinet 1 and busbar 6 on modular battery cabinet 2

Install Busbars in 523 mm (20.59 in) UPS System with the UPS Placed to the Right

Front view

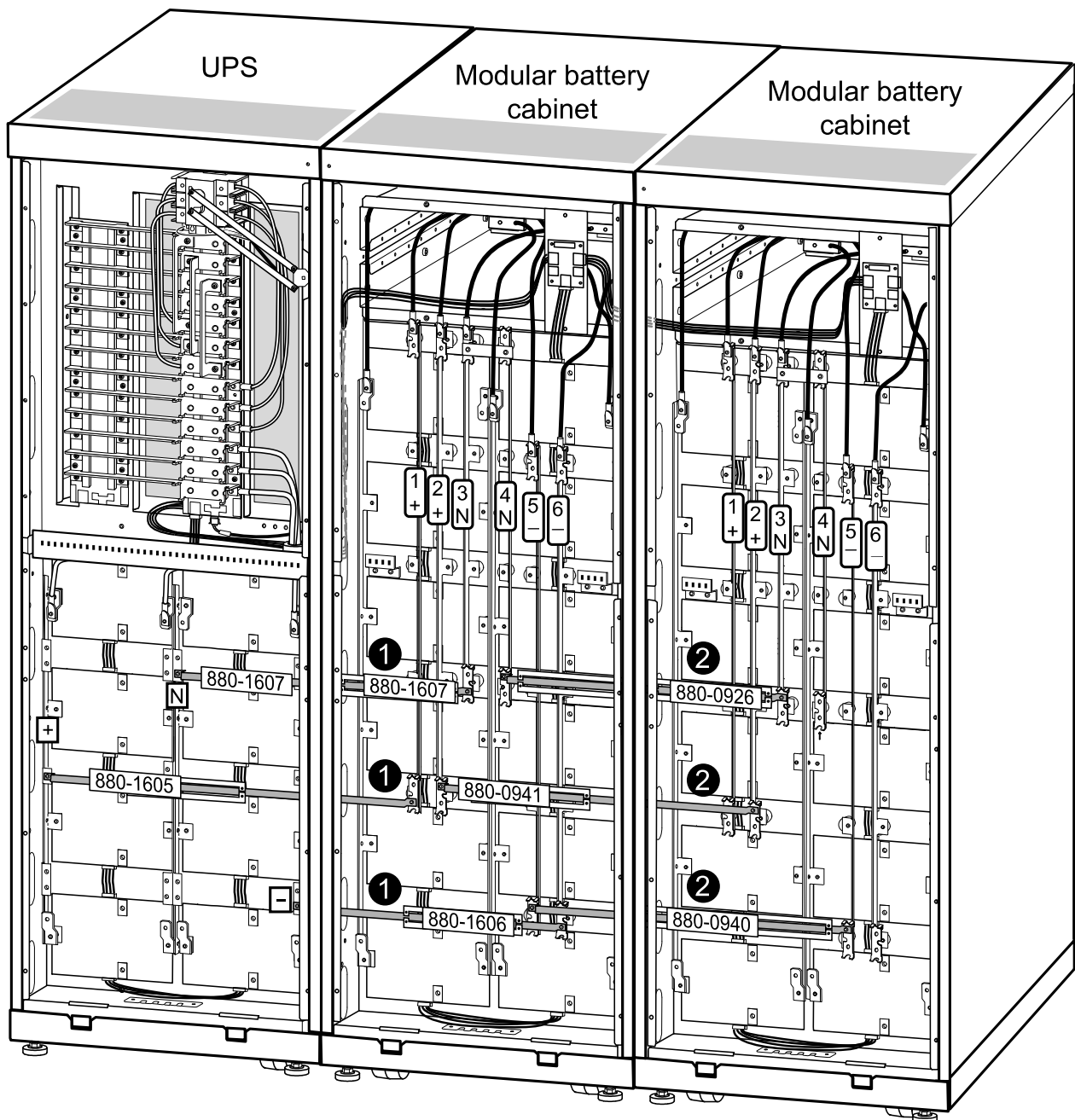

1. Install the following buying kit busbars between the UPS and modular battery cabinet 1:
 - 880-1607 between vertical busbar N on the UPS and busbar 3 on modular battery cabinet 1
 - 880-1605 between vertical busbar (+) on the UPS and busbar 1 on modular battery cabinet 1
 - 880-1606 between vertical busbar (-) on the UPS and busbar 6 on modular battery cabinet 1

2. Install the following buying kit busbars between the two modular battery cabinets:
 - 880-0926 between vertical busbar 4 on modular battery cabinet 1 and vertical busbar 3 on modular battery cabinet 2
 - 880-0941 between vertical busbar 2 on modular battery cabinet 1 and vertical busbar 2 on modular battery cabinet 2
 - 880-0940 between vertical busbar 5 on modular battery cabinet 1 and vertical busbar 5 on modular battery cabinet 2

Install Busbars in 352 mm (13.85 in) UPS System with the UPS Placed to the Right

Front view

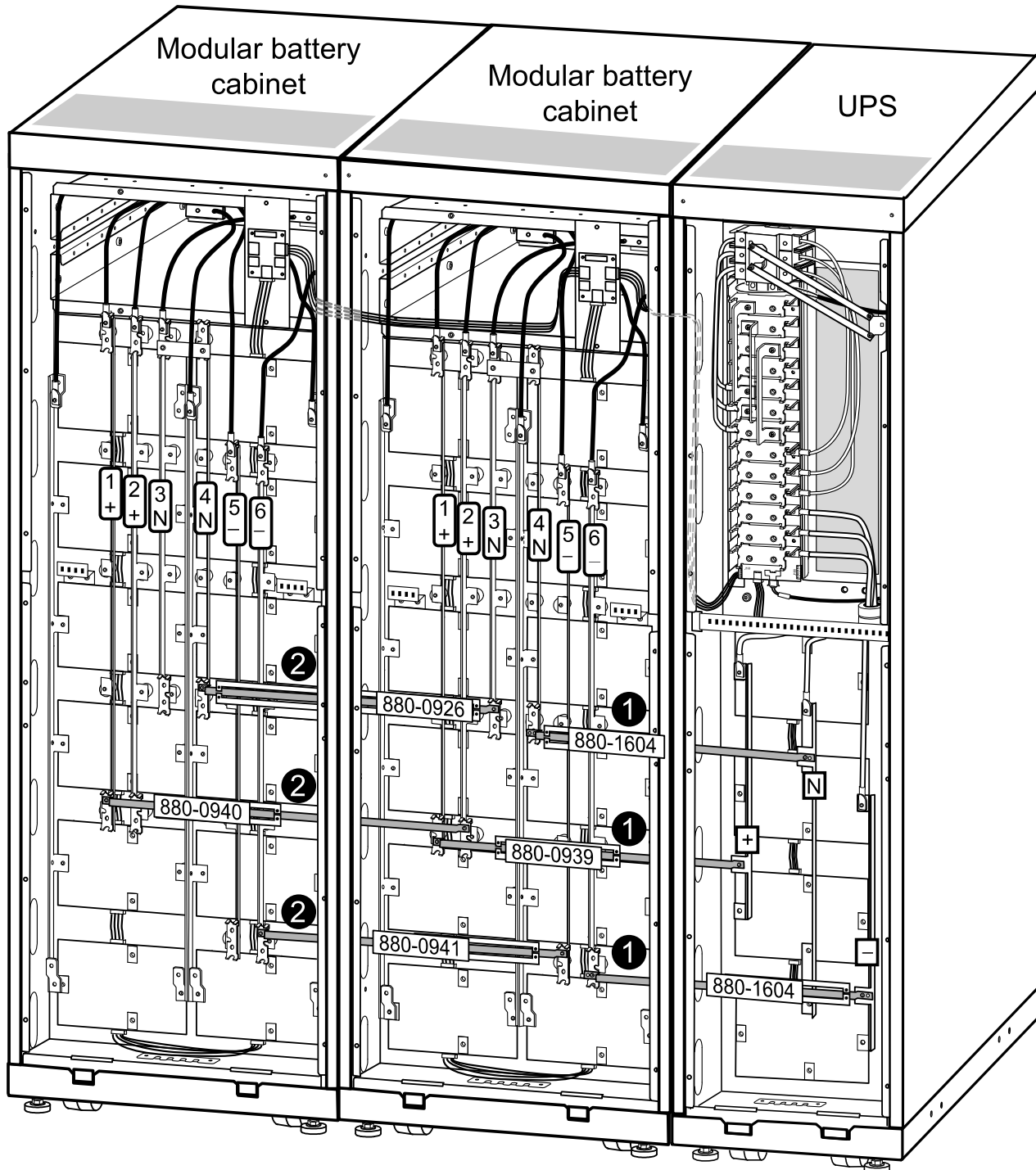

1. Install the following buying kit busbars between the UPS and modular battery cabinet 1:
 - 880-1604 between vertical busbar N on the UPS and busbar 4 on modular battery cabinet 1
 - 880-0939 between vertical busbar (+) on the UPS and busbar 1 on modular battery cabinet 1
 - 880-1604 between vertical busbar (-) on the UPS and busbar 6 on modular battery cabinet 1
2. Install the following buying kit busbars between two modular battery cabinets:
 - 880-0926 between vertical busbar 3 on modular battery cabinet 1 and busbar 4 on modular battery cabinet 2
 - 880-0940 between vertical busbar 2 on modular battery cabinet 1 and busbar 1 on modular battery cabinet 2
 - 880-0941 between vertical busbar 5 on modular battery cabinet 1 and busbar 6 on modular battery cabinet 2

Install Busbars in 352 mm (13.85 in) UPS System with the UPS Placed to the Left

Front view

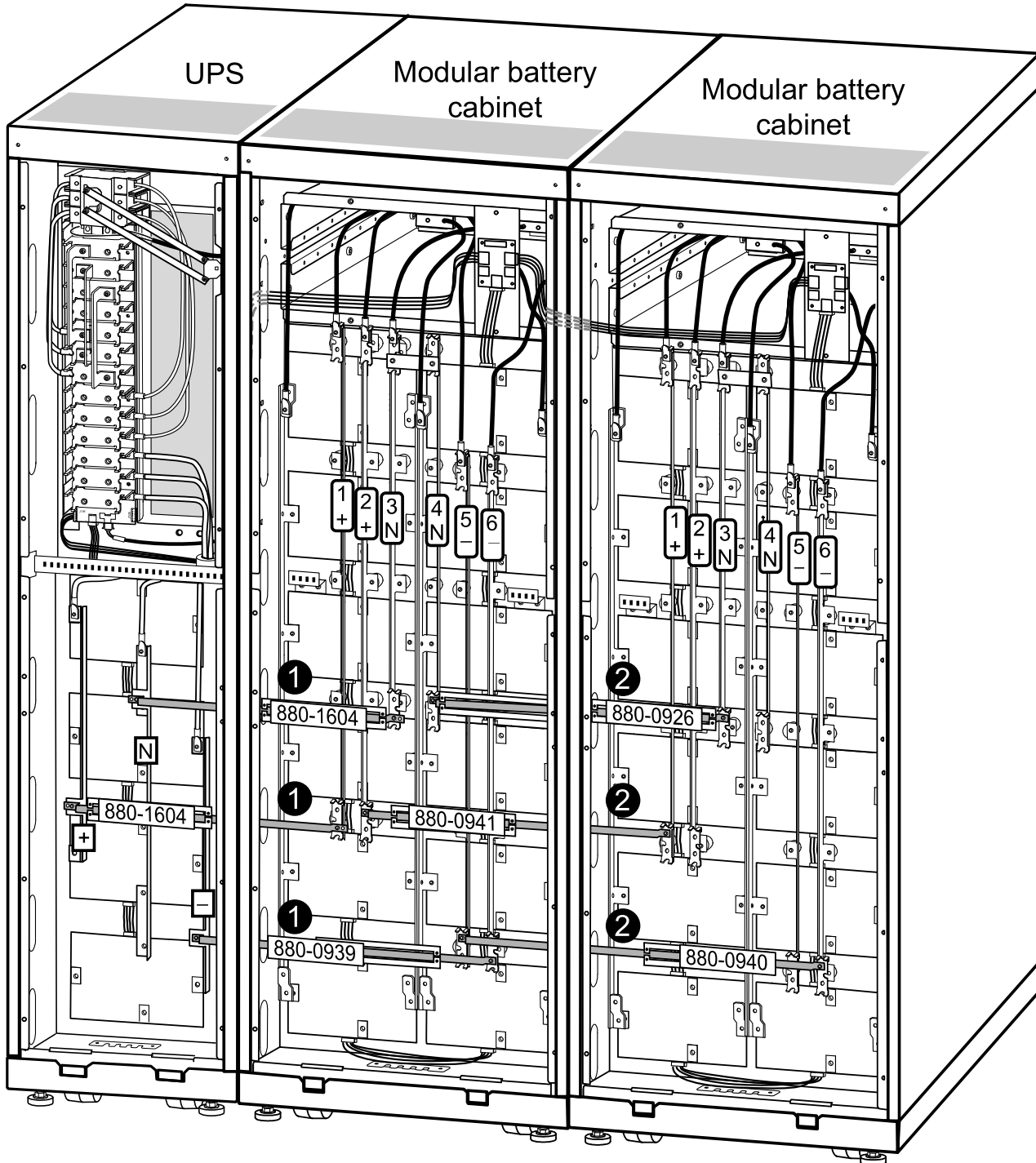

1. Install the following buying kit busbars between the UPS and modular battery cabinet 1:
 - 880-1604 between vertical busbar N on the UPS and busbar 3 on modular battery cabinet 1
 - 880-1604 between vertical busbar (+) on the UPS and busbar 1 on modular battery cabinet 1
 - 880-0939 between vertical busbar (-) on the UPS and busbar 6 on modular battery cabinet 1

2. Install the following baying kit busbars between two modular battery cabinets:
 - 880-0926 between vertical busbar 4 on modular battery cabinet 1 and vertical busbar 3 on modular battery cabinet 2
 - 880-0941 between vertical busbar 2 on modular battery cabinet 1 and vertical busbar 1 on modular battery cabinet 2
 - 880-0940 between vertical busbar 5 on modular battery cabinet 1 and vertical busbar 6 on modular battery cabinet 2

Connect Battery Power in Installations with Cables

Connect Battery Cables Between the UPS and the Modular Battery Cabinet

DANGER

HAZARD OF ELECTRIC SHOCK, EXPLOSION OR ARC FLASH

Before carrying out the steps below, the system must be in total power off and the batteries must be removed.

Failure to follow these instructions will result in death or serious injury.

DANGER

HAZARD OF ELECTRIC SHOCK, EXPLOSION OR ARC FLASH

Each stand-alone cabinet must be separately connected to the equipotential bonding system (protective earthing).

Failure to follow these instructions will result in death or serious injury.

NOTE: The terminals are only suitable for connection of copper cables (not supplied).

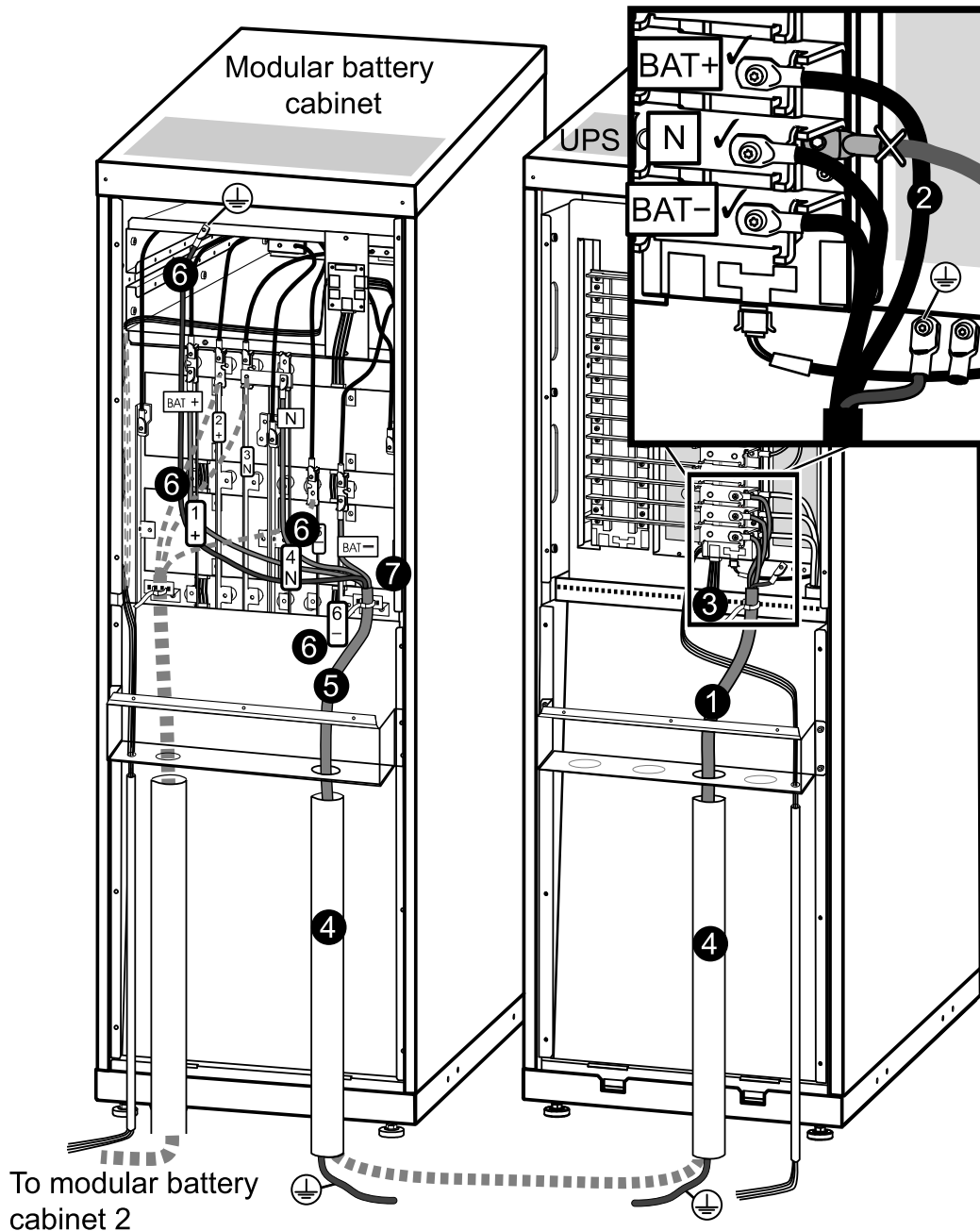

1. In the UPS, feed the battery cables up through the conduit box or through the transparent cable route bracket (not shown).
2. Connect the BAT+, BAT-, N, and ground cables to the outer part of the busbars in the UPS as shown.
3. Fasten the battery cables to the perforated bracket with cable ties.
4. Equip the battery cables with conduits (if applicable).
5. In the modular battery cabinet, feed the battery cables up through the conduit box (if applicable) to the cable landing area.
6. Connect the (+) cable to busbar number 1 (+), connect the N cable to busbar number 4 (N), the (-) cable to busbar number 6 (-), and the ground cable to the terminal in the top of the cabinet. Bundle the battery cables using the supplied cable ties.
7. Fasten the battery cables to the perforated bracket with cable ties.
8. Attach the top part of the conduit box (if applicable).

Connect Battery Cables Between Two Modular Battery Cabinets

⚠ DANGER

HAZARD OF ELECTRIC SHOCK, EXPLOSION OR ARC FLASH

Before carrying out the steps below, the system must be in total power off and the batteries must be removed.

Failure to follow these instructions will result in death or serious injury.

⚠ DANGER

HAZARD OF ELECTRIC SHOCK, EXPLOSION OR ARC FLASH

Each stand-alone cabinet must be separately connected to the equipotential bonding system (protective earthing).

Failure to follow these instructions will result in death or serious injury.

NOTE: The terminals are only suitable for connection of copper cables (not supplied).

Rear view

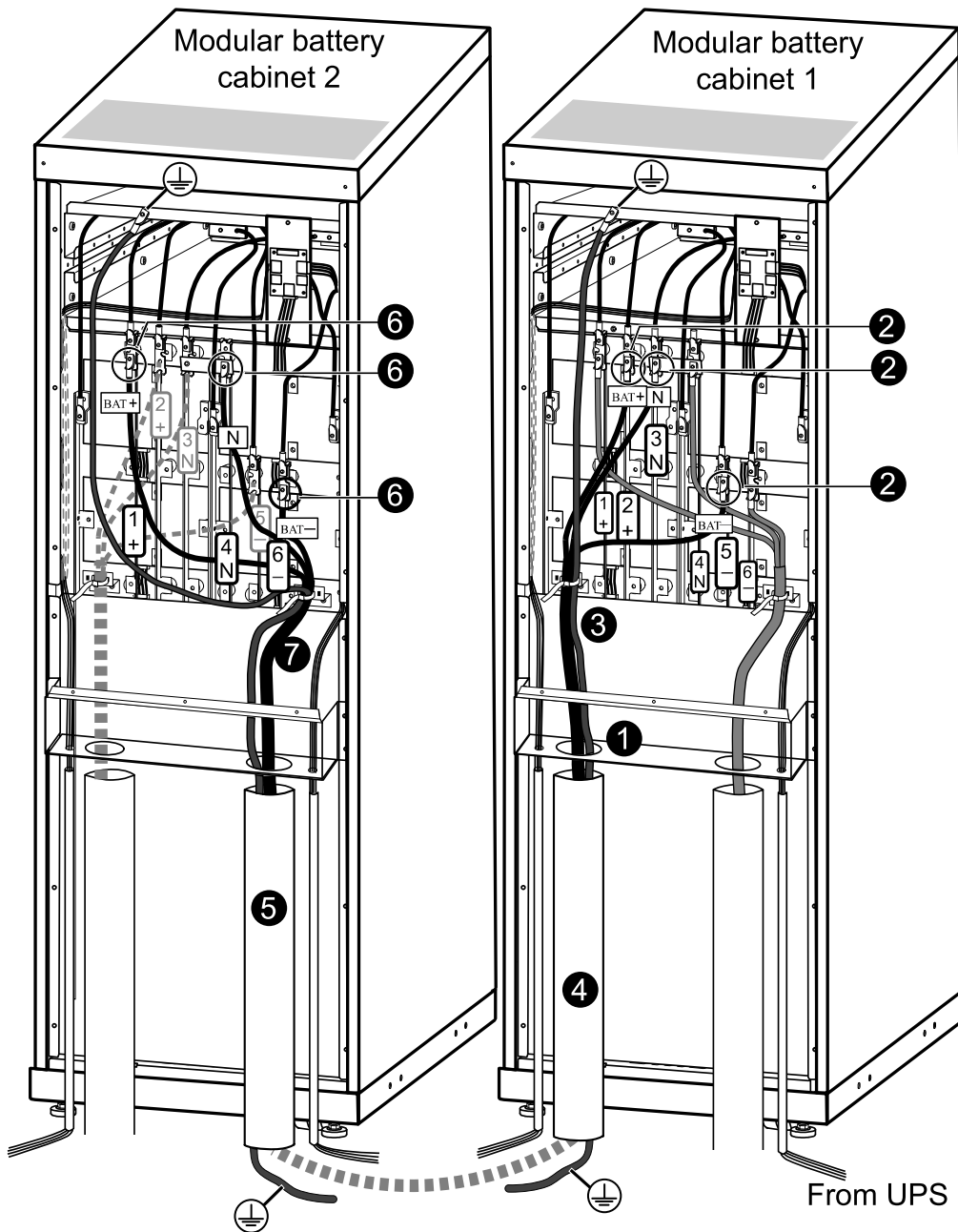

1. Feed the battery cables up through the conduit box on modular battery cabinet 1 or through the transparent cable route bracket (not shown) to the cable connection area.
2. Connect the (-) cable to busbar number 5 (-), the N cable to busbar number 3 (N), the (+) cable to busbar number 2 (+) in modular battery cabinet 1, and the ground cable to the terminal in the top of the cabinet.
3. Fasten the battery cables to the perforated bracket with cable ties.
4. Equip the battery cables with conduits (if applicable).
5. Feed the battery cables up into the conduit box on modular battery cabinet 2.
6. Connect the (-) cable to busbar number 6 (-), the N cable to busbar number 4 (N), and the (+) cable to busbar number 1 (+) in modular battery cabinet 2, and the ground cable to the terminal in the top of the cabinet. Bundle the battery cables using the supplied cable ties.
7. Fasten the battery cables to the perforated bracket with cable ties.
8. Attach the top part of the conduit box (if applicable).

Connect the Power Cables to the UPS

Single Mains without MBP

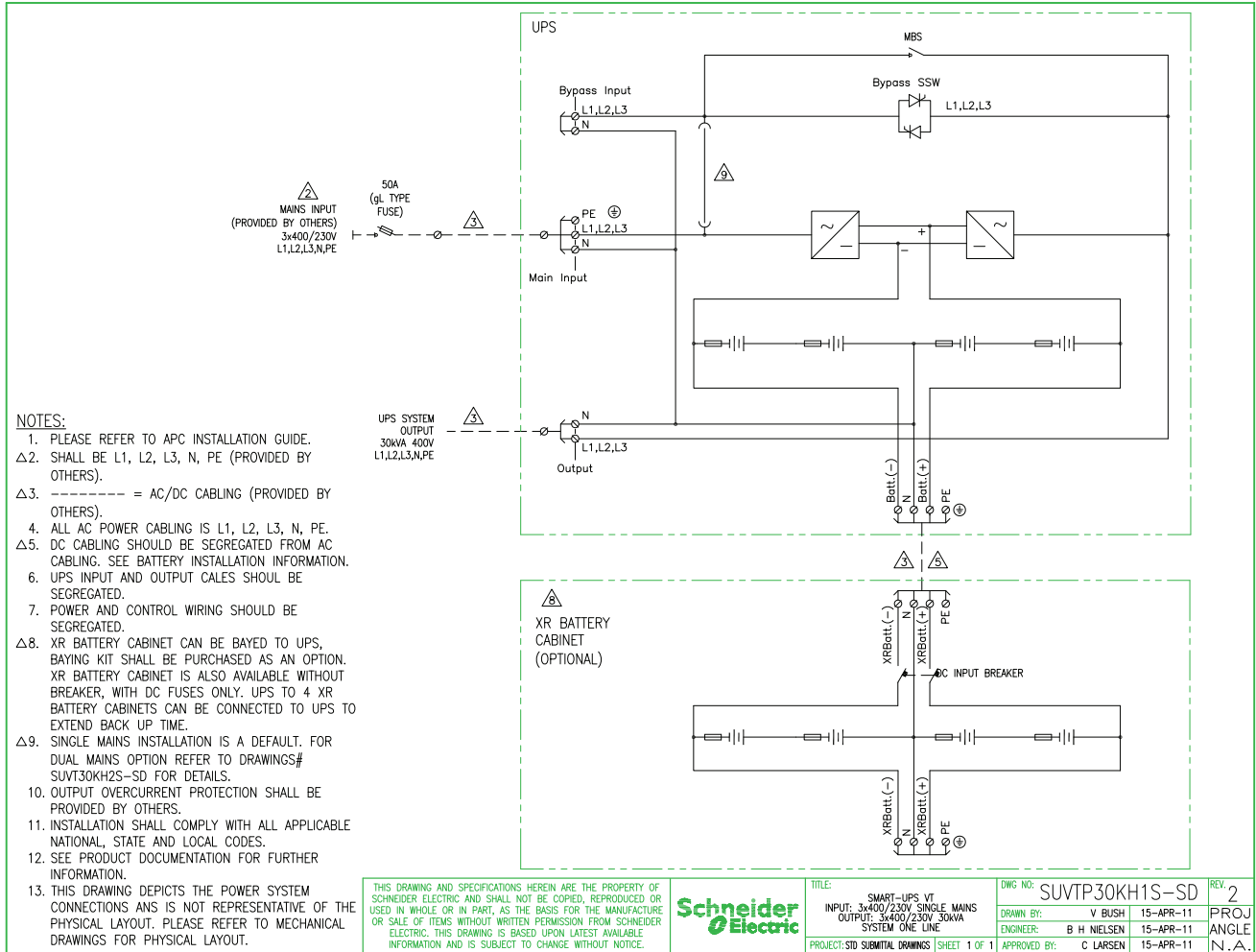

Dual Mains without MBP

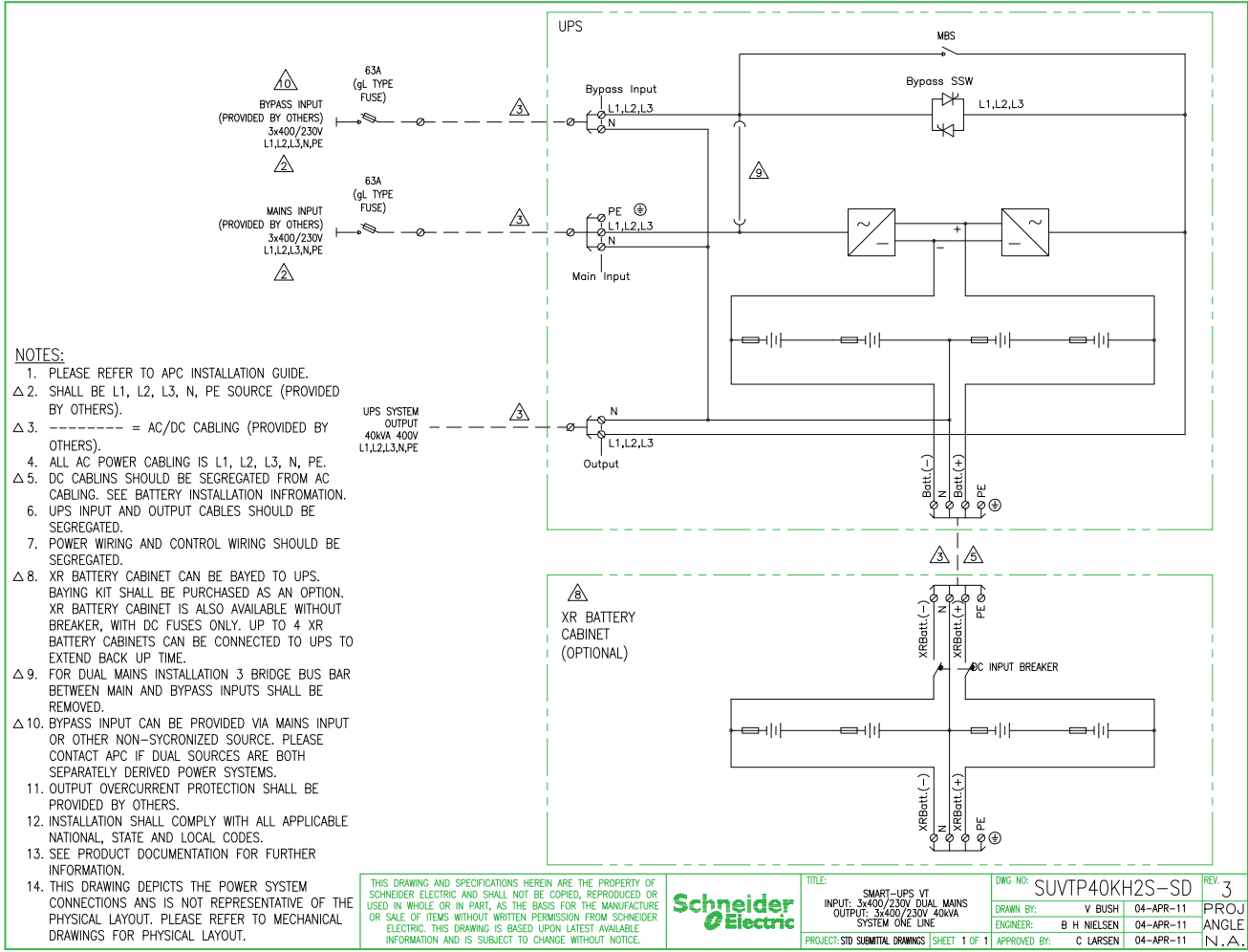

Single Mains with MBP

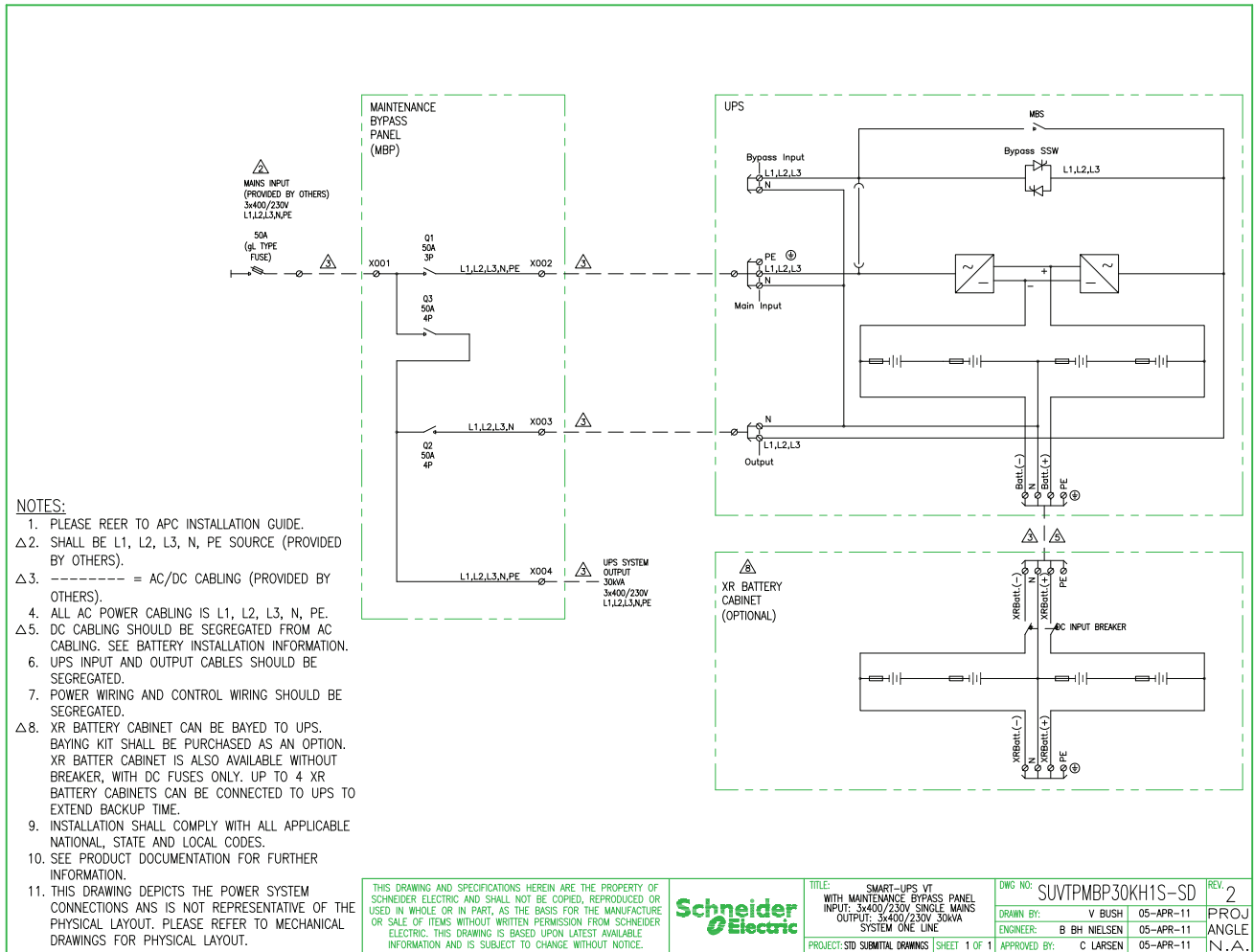

Prepare for Cables

Bottom Cable Entry

1. From the rear of the UPS, loosen the six M4 screws from the upper cover (the cable landing area) on the back and remove.

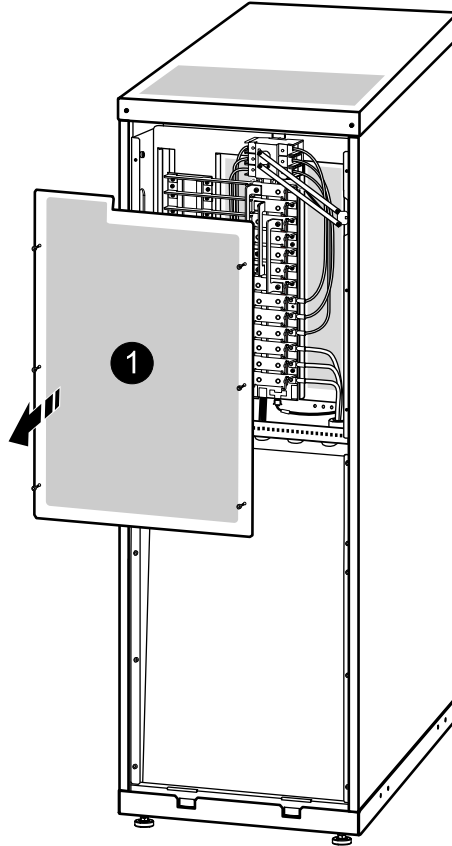

2. Route the cables from the slanted back plate, up through the punched bracket, and into the cable landing area.

3. Fasten the cables with cable ties.

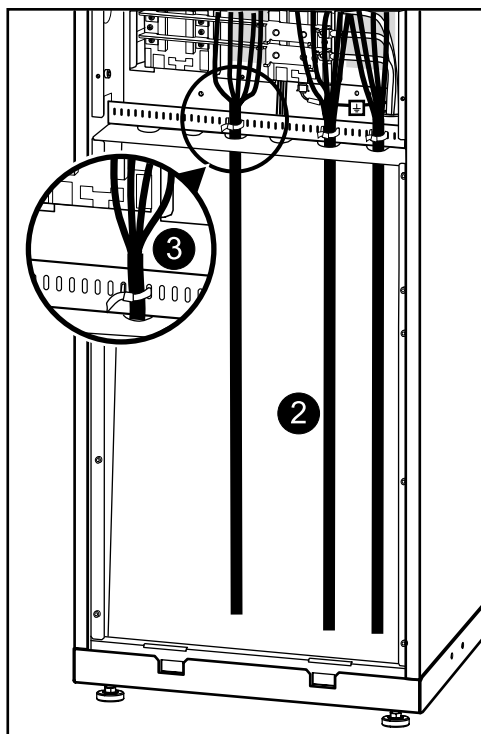

NOTE: A conduit box (part no. SUVTOPT001 or SUVTOPT002) is available as an option.

Connect the Input, Bypass, and Output Cables

⚠ DANGER

HAZARD OF ELECTRIC SHOCK, EXPLOSION AND ARC FLASH

Use **ONLY** compression type lugs. Do not loosen or add cables to any factory preinstalled cables on busbars. Use the outer part of the busbar for connection only.

Failure to follow these instructions will result in death or serious injury.

NOTE: The terminals are only suitable for connection of copper cables.

NOTE: If 3-wiring is required, do not connect the neutral to the input cable landings and the output cable landings.

3:3 Single Mains

⚠ DANGER

HAZARD OF ELECTRIC SHOCK, EXPLOSION, OR ARC FLASH

Connect only cables to the outer part of the busbars, never to the inner part of the busbars, as shown on illustration.

Failure to follow these instructions will result in death or serious injury.

1. Connect the AC input cables and the neutral to the input cable landings.
2. Connect the AC output cables and the neutral to the output cable landings.

3. Connect the ground cables to the studs (earth symbol beneath) using a screw.

Rear View of the UPS Cabinet

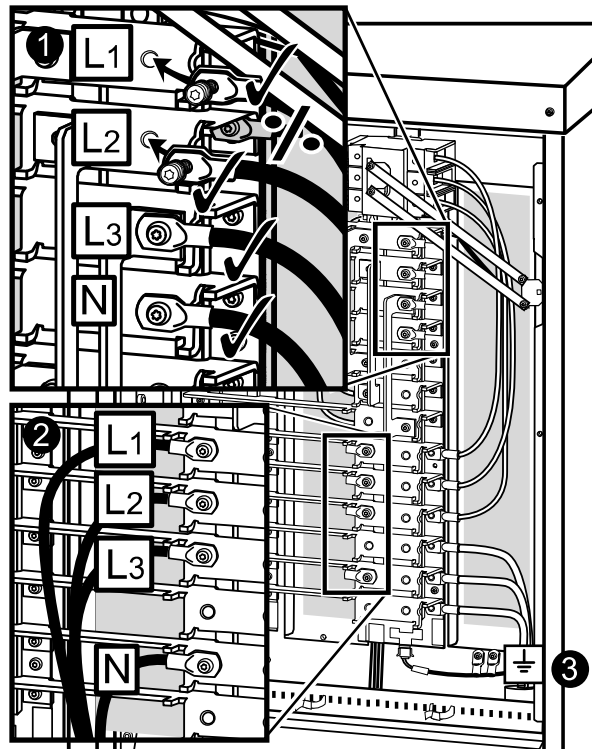

3:3 Dual Mains

⚠ DANGER

HAZARD OF ELECTRIC SHOCK, EXPLOSION, OR ARC FLASH

Connect only cables to the outer part of the busbars, never to the inner part of the busbars, as shown on illustration.

Failure to follow these instructions will result in death or serious injury.

1. Remove the three busbars A, B, and C by removing two M6 screws from each busbar.

Rear View of the UPS Cabinet

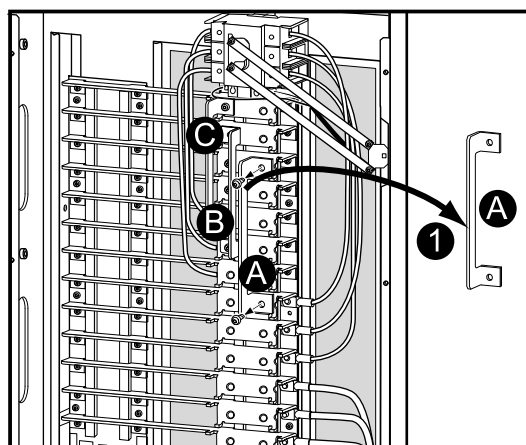

2. Connect the AC input cables and the neutral to the input cable landings.
3. Connect the bypass cables and the neutral to the bypass cable landings.
4. Connect the output cables and the neutral to the output cable landings.

- Connect the ground cables to the studs (earth symbol beneath) using a screw.

Rear view

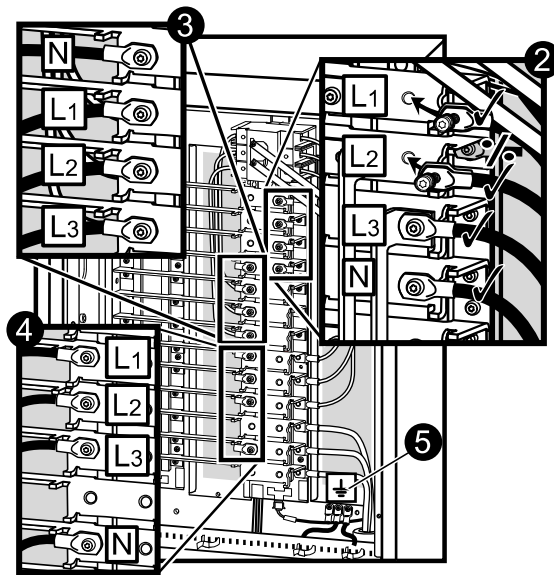

Connect the Battery Cables to Third Party Batteries (if Applicable)

⚠ DANGER

HAZARD OF ELECTRIC SHOCK, EXPLOSION, OR ARC FLASH

Connect only cables to the outer part of the busbars, never to the inner part of the busbars, as shown on illustration.

Failure to follow these instructions will result in death or serious injury.

- Connect the battery cables BAT+, BAT-, and N to the battery cable landings. Bundle the battery cables using the supplied cable ties.

Rear View of the UPS Cabinet

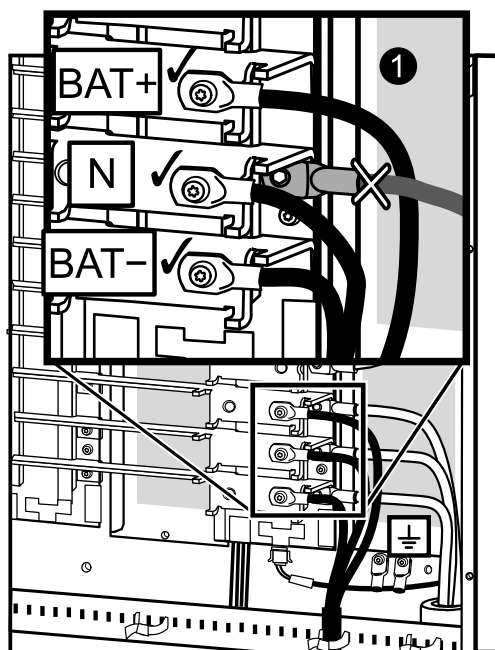

Connect the Communication Cables

Prepare for Communication Cables

⚠ DANGER

HAZARD OF ELECTRIC SHOCK, EXPLOSION OR ARC FLASH

Make sure that the UPS is completely OFF as the connectors are very close to the power busbars.

Failure to follow these instructions will result in death or serious injury.

NOTE: Before connecting the communication cables, place the two supplied ferrites over the communication cables. Run the cable three times through the ferrite to reduce noise.

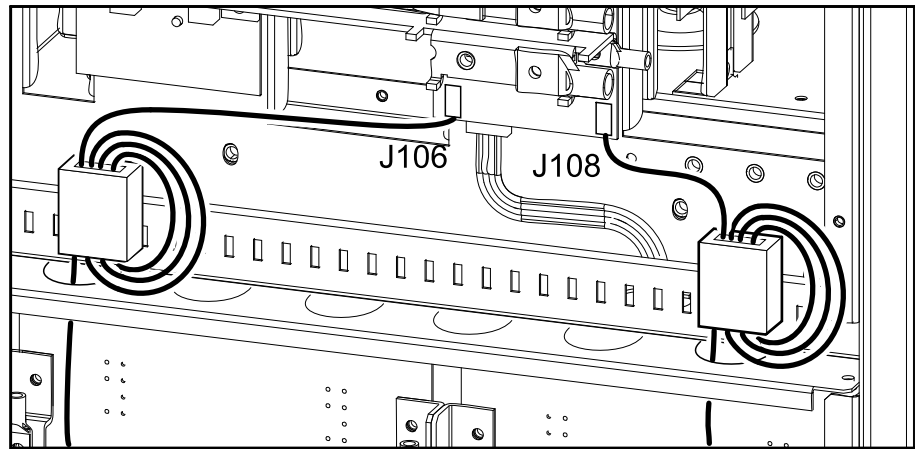

Overview of the Pin Connections

J108 pin connections:

1. Normally open EPO
2. Normally open EPO return
3. Normally closed EPO
4. Normally closed EPO return
5. +24 V SELV supply
6. SELV ground

Rear view

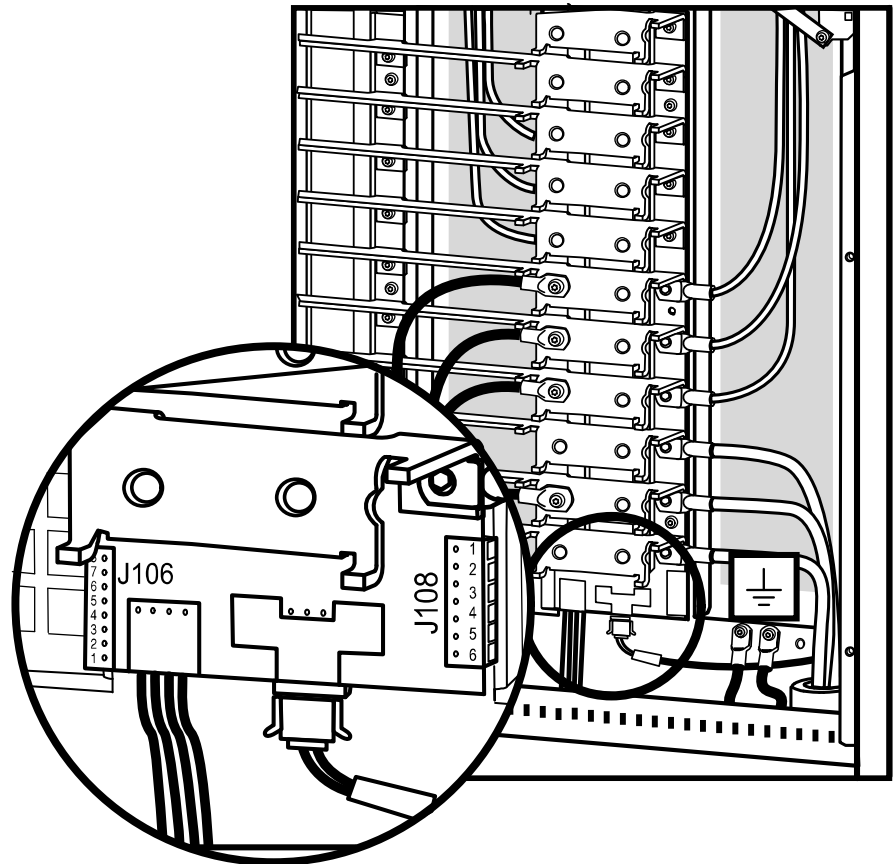

J106 pin connections:

1. Battery measurement return³
2. Max. battery temperature³
3. Battery unit quantity³
4. Battery measurement supply³
5. Q3 active
6. Q3 active return
7. External control of charging
8. Ext. charging control return

J106

Pins 1 to 4 are for battery measurement (only applicable to Galaxy 3500 modular battery cabinets).

Pins 5 and 6 are for external maintenance bypass Q3 (auxiliary switch N/C type). When Q3 is closed, signals are fed back to the UPS controller.

Pins 7 and 8 are for external charge control. When 7 and 8 are closed, the UPS charges batteries with a predefined percentage (0–25–50–75–100%) of the maximum charging power. To be used in generator applications, or if special codes require control of charging. When Q3 is closed, signals are fed back to the UPS controller.

Connect EPO in Single Systems

- Use only 1-1½ mm² copper wire for the connection of the EPO (Emergency Power Off) and other optional equipment.
- The UPS must be connected to either a dry contact or a 24 VDC EPO switch.

The external EPO +24 VDC, 1500 mA circuit can be supplied through other vendors.

³ Should be used with Schneider Electric modular battery cabinets

1. Connect the EPO cable using one of the following four wiring configurations:

- **Dry Contacts Normally Open:** EPO is activated when pin 1 is connected to pins 3 and 5. Connections: 2-4-6, 3-5, and 1 .

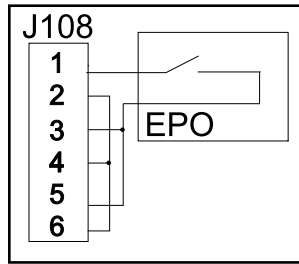

- **+24 V Normally Open:** EPO is activated when an isolated SELV 24 VDC voltage is supplied on pin 1 with reference to pin 2. Connections: 3-5 and 4-6.

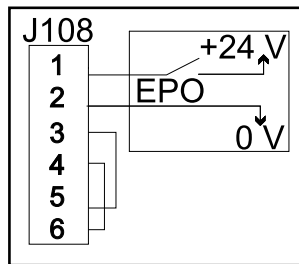

- **Dry Contacts Normally Closed:** EPO is activated when a connection from pin 3 to 5 is opened. Connections: 4-6.

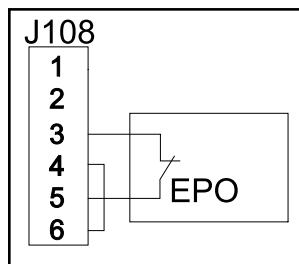

- **+24 V Normally Closed:** EPO is activated when a SELV 24 VDC voltage is removed from pin 3 with reference to pin 4.

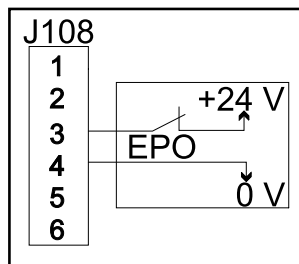

Connect EPO in Parallel Systems

In parallel systems each UPS unit must have a separate dry contact (voltage free) external to the UPS connected to J108.

⚠ CAUTION

RISK OF ERRATIC UPS BEHAVIOR

For parallel and separate systems with common EPO, each UPS unit must be connected to a separate dry contact external to the UPS, because parallel EPO wiring between more UPS units can result in erratic UPS behavior.

Failure to follow these instructions can result in injury or equipment damage.

Schneider Electric recommends a **Dry Contacts Normally Closed EPO** installation of the UPS units in parallel – shown in the illustration below for four UPSs in parallel. Each UPS is connected to a separate dry contactor.

Dry Contacts Normally Closed EPO installation

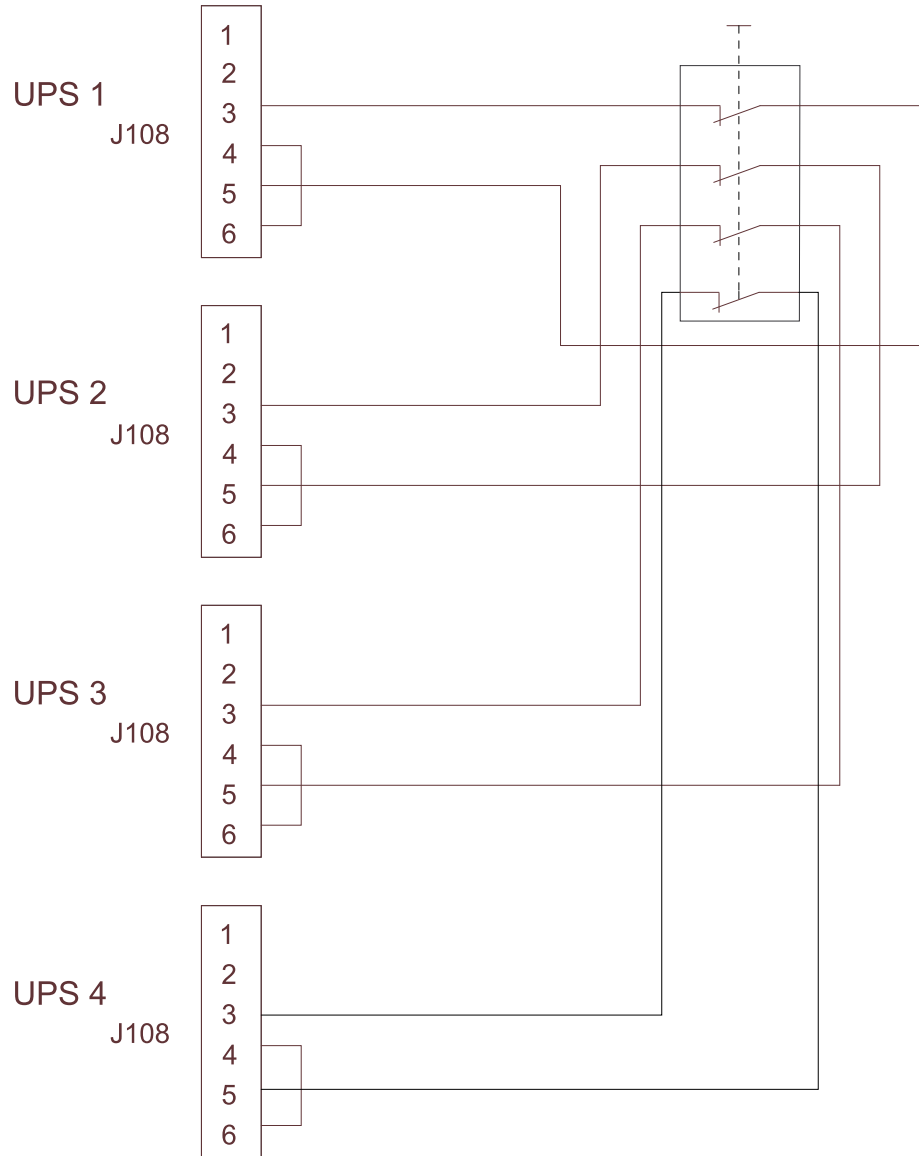

Connect Communication Cables between UPS and Modular Battery Cabinet

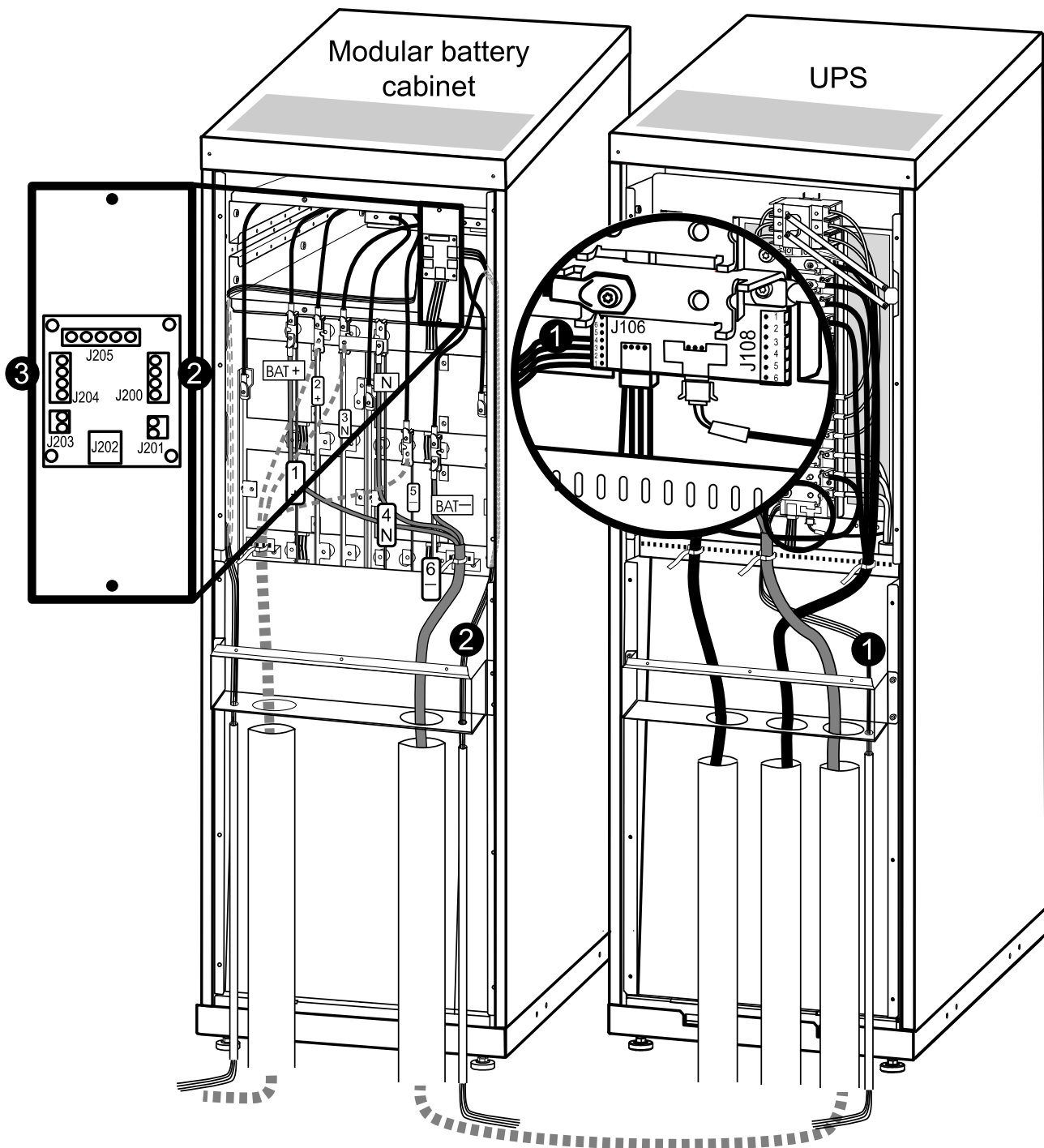

1. Feed the communication cable from pin connection J106 in the UPS down through the conduit (if applicable).
2. Run the communication cable up into the modular battery cabinet conduit and connect it to pin connection J200.
3. If you use a second modular battery cabinet, run the communication cable from pin connection J204 in modular battery cabinet 1 to pin connection J200 in modular battery cabinet 2.

Connect Schneider Electric Communication Options

NOTE: The cable routing of the power chute software and the temperature sensor is identical.

NOTE: The temperature sensor is provided in a plastic bag attached behind the front panel in the UPS.

1. Remove the two screws from the cable inlet at the front and remove the cable inlet plate.
2. Guide the communication cable through the hole in the bottom plate and up through the cable inlet.
3. Guide the communication cable through the side panel hole and run the communication cable upwards inside the panel.
4. Pull the communication cable out of the side panel through the hole closest to the network management card area.
5. Plug the communication cable into the probe socket/PowerChute inlet.

- Reattach the cable inlet plate.

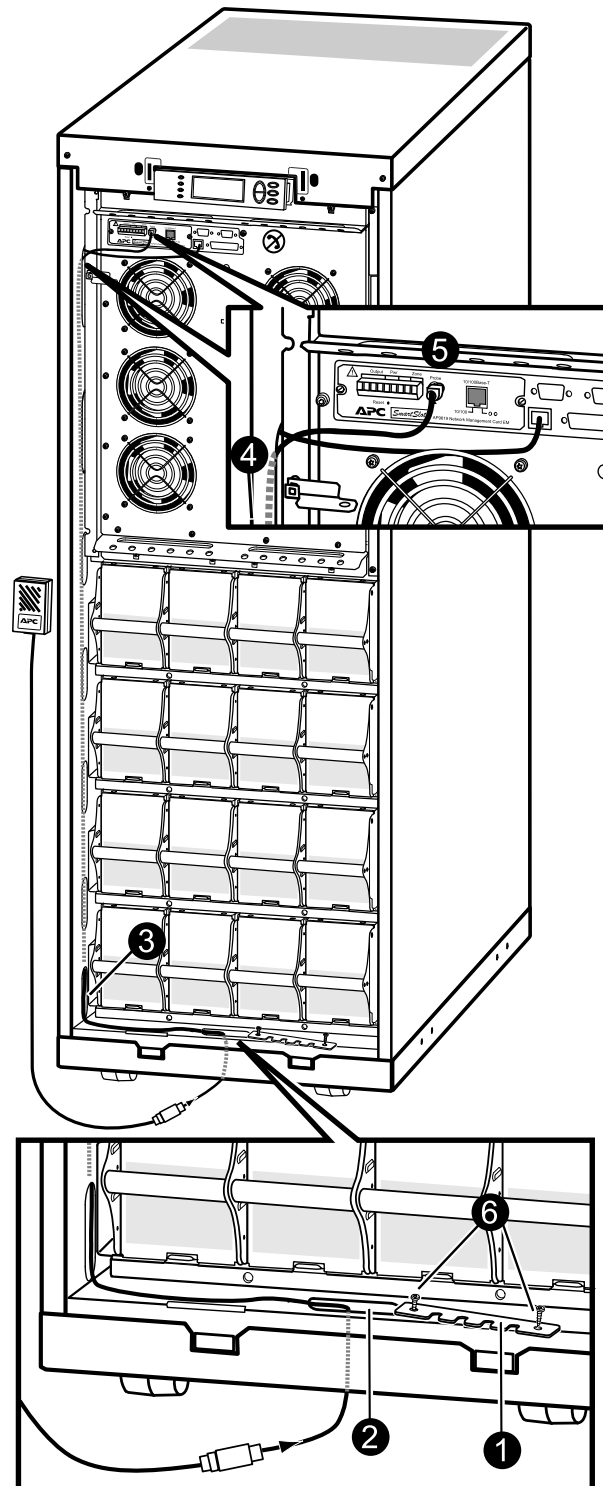

Connect Communication Cables in Parallel System

Overview of the PBus Cables

NOTE: The cables must be run by the electrician but not attached. The field service engineer from Schneider Electric will attach all cables to the UPS unit(s) and install the parallel communication box. The below is for overview only.

NOTE: The PBus cables are labelled PBus 1 and PBus 2.

NOTE: PBus 1 cables must be kept together, and PBus 2 cables must be kept together. If you by mistake run a cable between a PBUS1 terminal and a PBUS2 terminal, you will be notified by the display.

NOTE: All PBus cables must be installed with a ferrite (supplied).

NOTE: If the configuration consists of only two UPS units, the terminators must be installed in UPS 1 and 2. With three UPS units, the terminators must be installed in UPS 1 and 3.

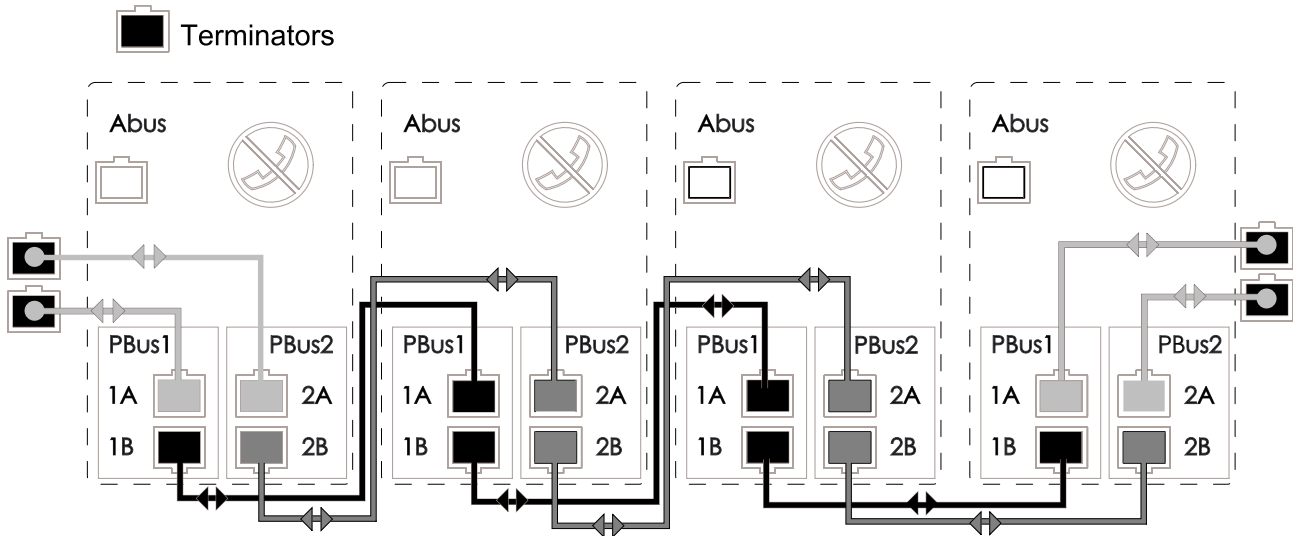

Prepare for Cables

Remove the Batteries

NOTE: See *Remove the Modular Batteries from the UPS Cabinet(s)*, page 21 for information on how to remove the modular batteries.

Run the Communication Cables

NOTE: The cabinets in a parallel system can be stand-alone cabinets, or they can be bayed together with interconnection plates. For stand-alone cabinets the communication cables can be run in conduits (if applicable).

There are three different ways of routing the communication cables:

- Stand-alone UPS cabinets (without conduits and without interconnection plates)
- UPS cabinets bayed together (without conduits and with interconnection plates)
- Stand-alone UPS cabinets and UPS cabinets bayed together (with conduits and optional interconnection plates)

Stand-Alone UPS Cabinets without Conduits and Interconnection Plates

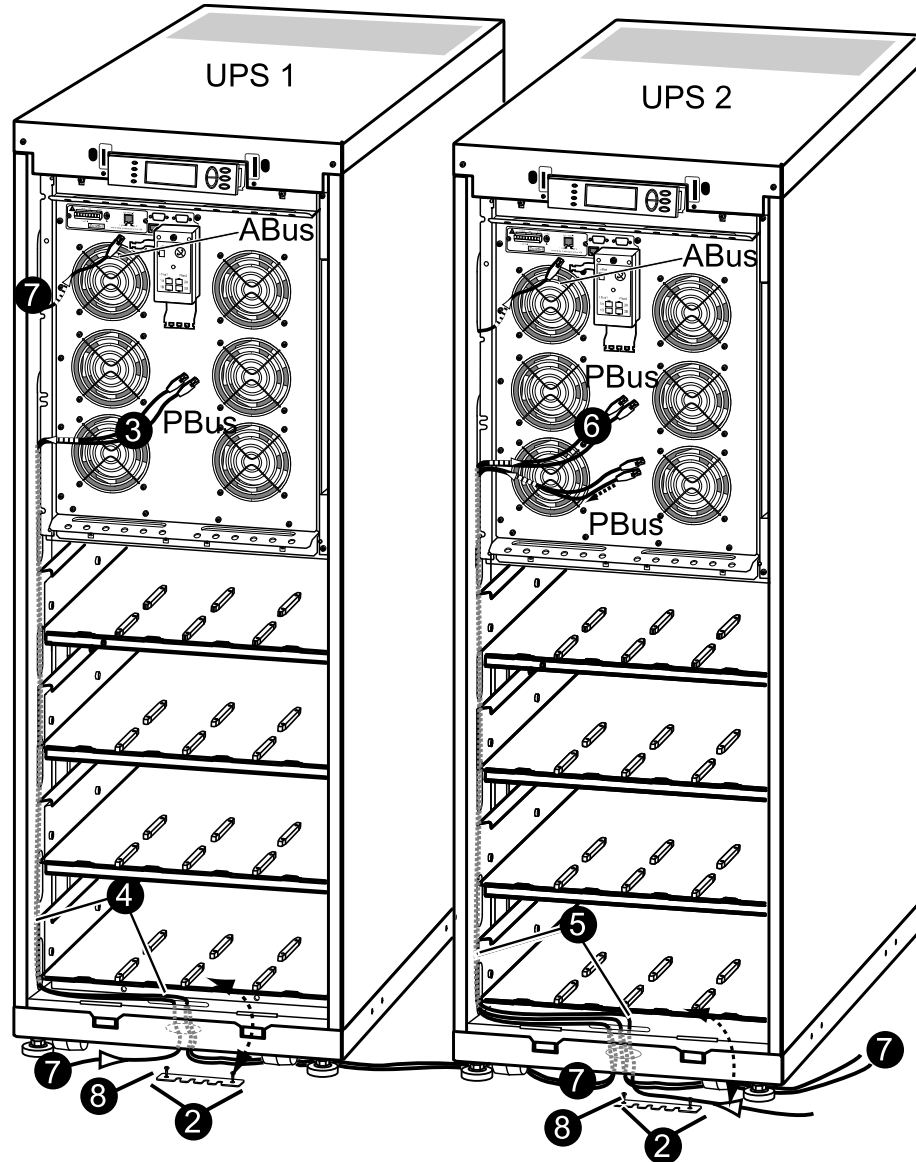

1. Remove the front panel (not shown).
2. Loosen the two screws from the cable inlet plates at the bottom plate of UPS 1 and UPS 2 and then remove the plates.
3. From UPS 1: Run the two PBus cables to the slots on the left side of the cabinet and down inside the panel.
4. From the lowest slot, fish out the cables from the side panel and run these down through the cable inlet and through the round hole at the bottom.
5. Run the PBus cables to UPS 2 and to the slots on the left side of the cabinet and up inside the panel.
6. Take out the PBus cables and leave these unattached to the parallel box.
7. Run the ABus cable from the maintenance bypass panel to the slots on the left side of the cabinet and up inside the panel the same way as for the PBus cables.
8. Reattach the cable inlet covers.
9. Fasten the cables with cables ties.
10. If applicable: Route the PBus and ABus cables into UPS 3 and UPS 4 in the same way.

UPS Cabinets Bayed Together without Conduits

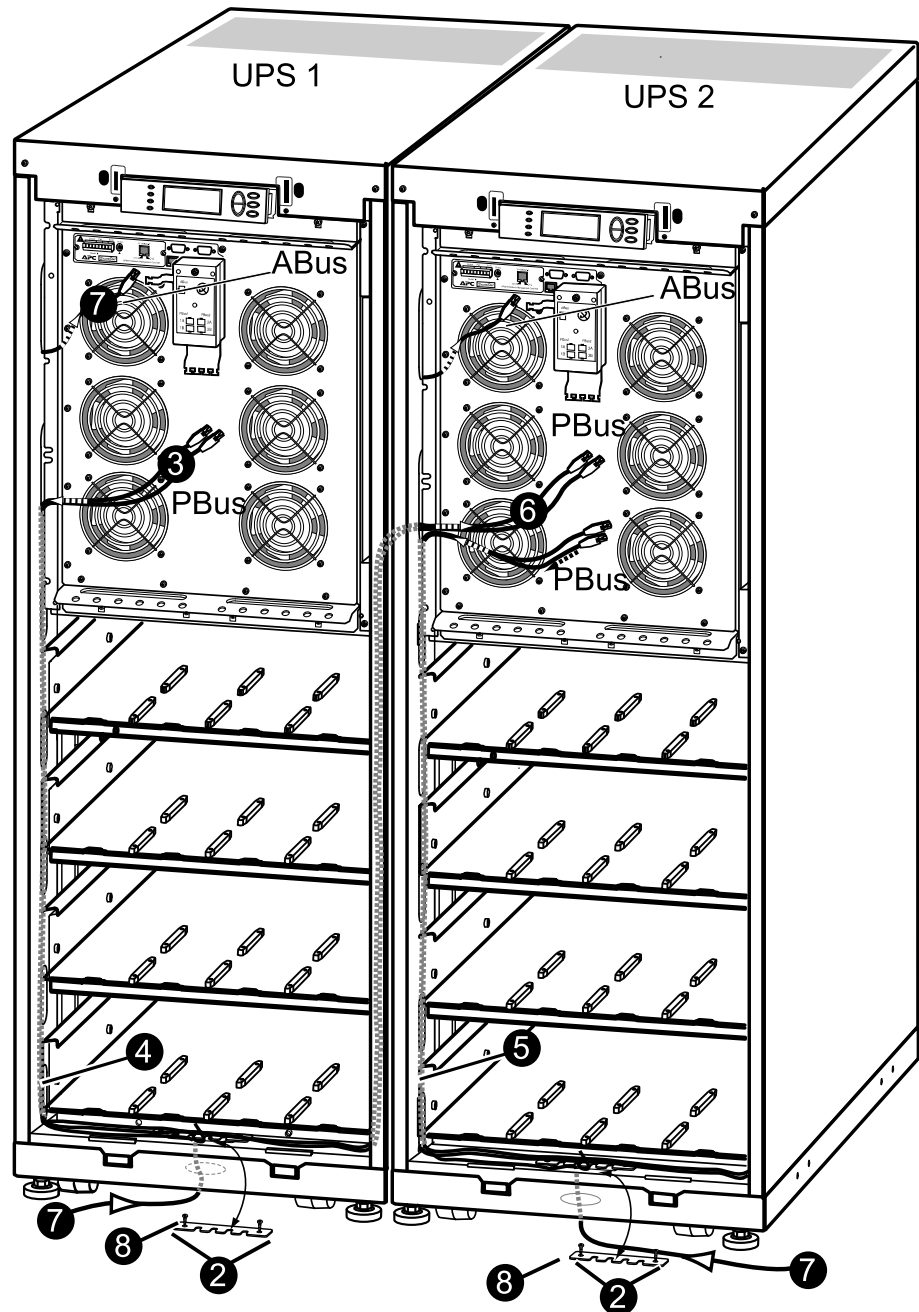

1. Remove the front panel and the top plate (not shown).
2. Loosen the two screws from the cable inlet plates at the bottom plate of UPS 1 and UPS 2 and then remove the plates.
3. From UPS 1: Run the two PBus cables to the slots on the left side of the cabinet and down inside the panel.
4. From the lowest slot, take out the cables from the side panel, run the cables across and through the cable inlets of the two side panels.
5. From the bottom of UPS 2, run the PBus cables to the slots on the left side of the cabinet and up inside the panel.
6. Take out the PBus cables and leave these unattached.
7. Run the ABus cable from the maintenance bypass panel to the slots on the left side of the cabinet and up inside the panel the same way as for the PBus cables.
8. Reattach the cable inlet cover plates.
9. Fasten the cables with cable ties.

10. If applicable: Route the PBus and ABus cables into UPS 3 and UPS 4 in the same way.

Stand-Alone UPS Cabinets or UPS Cabinets Bayed Together with Conduits

NOTE: When cabinets are assembled with interconnection plates and bolted together, the PBus cables can be run inside the cabinets and then only the ABus cable has to be run in a conduit (if applicable).

1. Remove the front panel (not shown).
2. Remove the top plate:
 - a. Loosen the six screws of the top plate (four in the front and two in the back).
 - b. Lift up from the back and push forward to free the plate.
 - c. Leave the plate unattached on top of the UPS.

Front and Rear View of the UPS

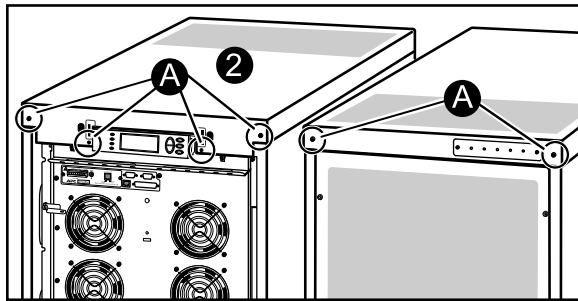

3. Remove the conduit plate at the back of the UPS top plate and drill holes centered in the small predrilled holes. 20 mm (3/4 in) is recommended for conduits.

Rear View of the Top Plate

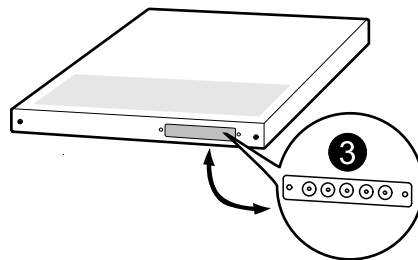

4. Run the ABus and the PBus cables through the conduit holes into the inside of the top plate on UPS 1. Leave the cables on top of the UPS.
5. Attach conduits with 20 mm (3/4 in) fittings (not supplied).
6. Run conduits with PBus cables to UPS 2. Pull the cables through the conduit plate on the top plate and leave the cables on top of the UPS as shown.
7. Attach conduits to UPS 2 with 20 mm (3/4 in) fittings (not supplied).

8. Run the ABus cables (in conduits if applicable) to the maintenance bypass panel.

Rear View of the UPS Cabinets

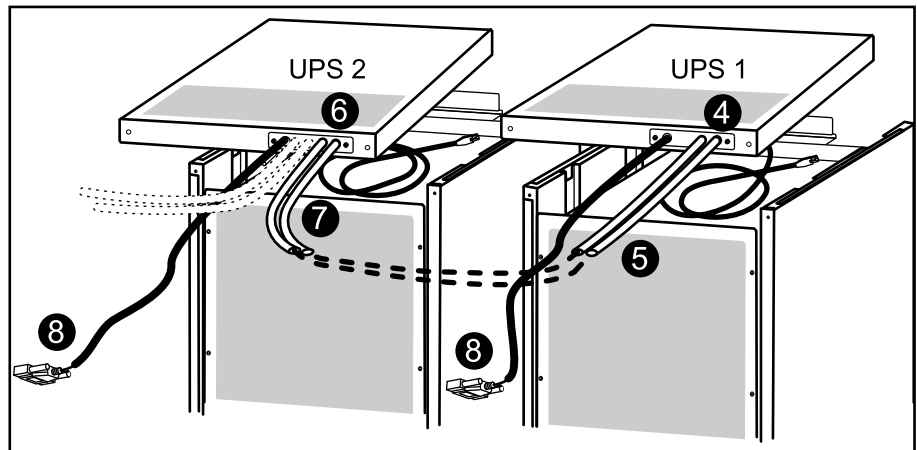

9. Reinstall the top plate.
10. If applicable: Route the PBus and ABus cables into UPS 3 and UPS 4 in the same way.

Final Mechanical Installation

Install Batteries and Connect Battery Securing Brackets

⚠ CAUTION

RISK OF EQUIPMENT DAMAGE

- Wait until the system is ready to be powered up before installing batteries in the system. The time duration from battery installation until the UPS system is powered up must not exceed 72 hours or 3 days.
- Batteries must not be stored more than six months due to the requirement of recharging. If the UPS system remains de-energized for a long period, we recommend that you energize the UPS system for a period of 24 hours at least once every month. This charges the batteries, thus avoiding irreversible damage.

Failure to follow these instructions can result in injury or equipment damage.

NOTE: The battery securing brackets are only used in non-seismic areas for stability, and when seismic battery locks are not part of the installation.

Front view

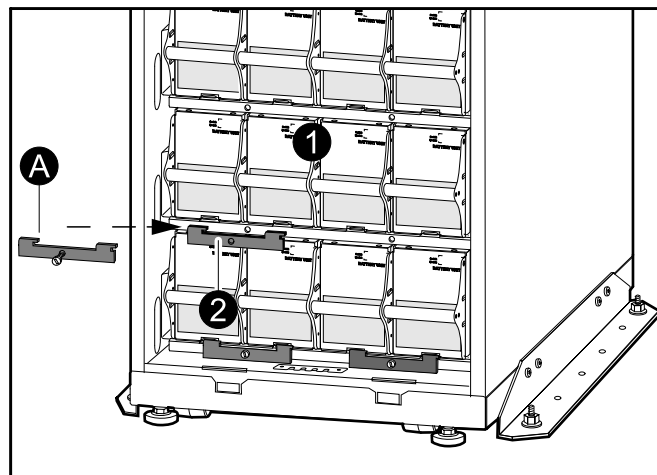

1. Install the batteries by pushing them all the way into the cabinet.
2. Optional: Rotate the battery securing brackets (A) 180° from how they were positioned on arrival and install them to hold the batteries firmly in place.

NOTE: Battery securing brackets are delivered with the UPS and modular battery cabinet and installed in front of the batteries. Battery securing brackets for additional batteries can be purchased. Refer to option SUVTOPT003: APC Smart-UPS VT Battery Lock Kit for one Battery Module (two batteries).

Reinstall the Top Plate and the Front Panel

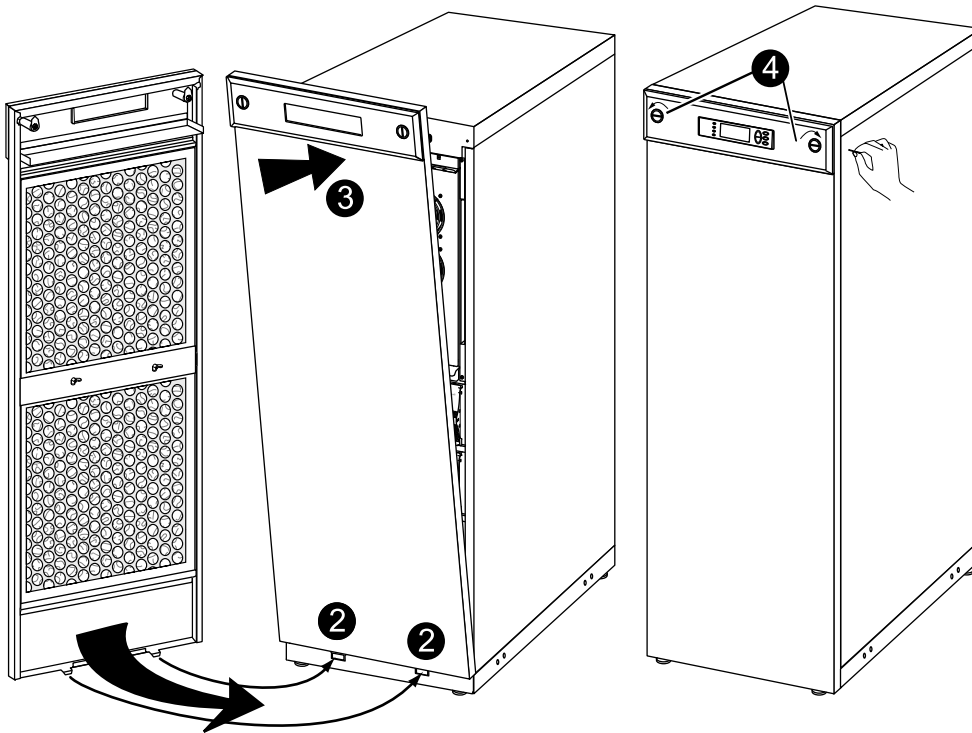

1. Reinstall the top plate by fastening the four screws at the front and the two screws at the back.
2. Insert the two tabs at the bottom of the front panel into the two slots at the bottom of the cabinet.
3. Push the front panel forward until it engages the locking devices at the top of the cabinet.
4. Use a screwdriver to set the lock mechanism to the locked position.

Schneider Electric
35 rue Joseph Monier
92500 Rueil Malmaison
France

+ 33 (0) 1 41 29 70 00

www.schneider-electric.com

As standards, specifications, and design change from time to time,
please ask for confirmation of the information given in this publication.

© 2012 – 2016 Schneider Electric. All rights reserved.

990–1986E-001