



by Schneider Electric

# User Manual Smart-UPS™ SRC10KUXI Tower/Rack-Mount 3U 220/230/240 Vac

## Important Safety Information

Read the instructions carefully to become familiar with the equipment before trying to install, operate, service or maintain it. The following special messages may appear throughout this manual or on the equipment to warn of potential hazards or to call attention to information that clarifies or simplifies a procedure.



The addition of this symbol to a Danger or Warning safety label indicates that an electrical hazard exists which will result in personal injury if the instructions are not followed.



This is the safety alert symbol. It is used to alert you to potential personal injury hazards. Obey all safety messages that follow this symbol to avoid possible injury or death.

### CAUTION

**CAUTION** indicates a potentially hazardous situation which, if not avoided, **can result in** minor or moderate injury.

### CAUTION

**CAUTION** addresses practices not related to physical injury including certain environmental hazards, potential damage or loss of data.

# Safety and General Information

Inspect the package contents upon receipt. Notify the carrier and dealer if there is any damage.

- This UPS is for indoor use only.
- Do not operate this UPS in direct sunlight, in contact with fluids, or where there is excessive dust or high humidity.
- Do not operate the UPS near open windows or doors.
- Be sure the air vents on the UPS are not blocked. Allow adequate space for proper ventilation.  
**Note:** Allow a minimum of 20 cm clearance on both front and rear sides of the UPS.
- Environmental factors impact battery life. Elevated ambient temperatures, poor quality utility power, and frequent discharges will shorten battery life. Follow the battery manufacturer recommendations.

## Electrical safety

- Connection to the branch circuit (mains) must be performed by a qualified electrician.
- The protective earth conductor for the UPS carries the leakage current from the load devices (computer equipment). An insulated ground conductor is to be installed as part of the branch circuit that supplies the UPS. The conductor must have the same size and insulation material as the grounded and ungrounded branch circuit supply conductors. The conductor will be green and with or without a yellow stripe.
- The grounding conductor is to be grounded to earth at the service equipment, or if supplied by a separately derived system, at the supply transformer or motor generator set.

## Battery safety

- Before installing or replacing the batteries, remove jewelry such as wristwatches and rings. High short circuit current through conductive materials could cause severe burns.
- Do not dispose of batteries in a fire. The batteries may explode.
- Do not open or mutilate batteries. Released electrolyte is harmful to the skin and eyes, and may be toxic.

## Hardwiring safety

- Verify that all branch circuit (mains) and low voltage (control) circuits are deenergized, and locked out before installing cables or making connections, whether in the junction box or to the UPS.
- Wiring by a qualified electrician is required.
- Check national and local codes before wiring.
- Select wire size and connectors according to national and local codes.
- Strain relief is required for all hardwiring.
- All openings allowing access to UPS hardwiring terminals must be covered. Failure to do so may result in personal injury or equipment damage.

## Product Description

The APC by Schneider Electric Smart-UPS™ is a high performance double conversion online uninterruptible power supply (UPS). The UPS helps to protect the connected electronic equipment from utility power blackouts, brownouts, sags, surges, small utility power fluctuations and large disturbances. The UPS also provides battery backup power for connected equipment until utility power returns to required levels or the batteries are discharged.

This user manual is available on the APC Web site, [www.apc.com](http://www.apc.com).

# Package Contents

The packaging is recyclable; save it for reuse or dispose of it properly.  
Check the UPS package contents:

Front bezel

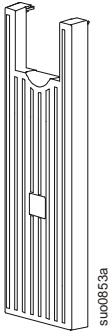

Battery connection cable

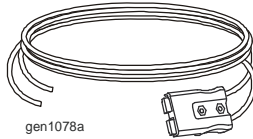

EPO connector

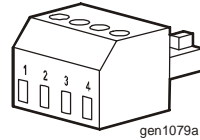

Serial communication cable

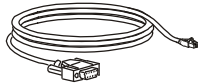

- 2 pairs stabilizer brackets
- 4 flat head screws to secure tower stabilizer brackets to the UPS

- Input terminal block cover
- 1 securing screw

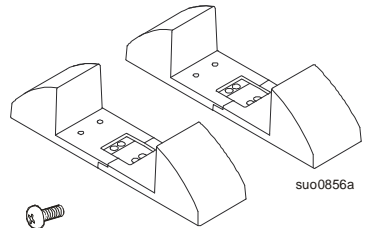
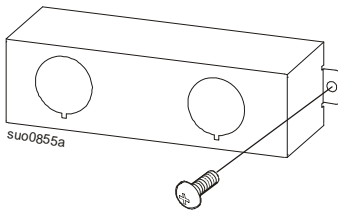

**NOTE:** The model and serial numbers are located on a small, rear panel label. For some models, an additional label is located on the chassis behind the front bezel.

## Optional Accessories

Refer to the APC Web site, [www.apc.com](http://www.apc.com), for available accessories.

- Rail Kit SURTRK2
- Temperature Probe AP9335T/TH  
**Note:** Use the temperature probe with the UPS to enhance the battery life.
- UPS Network Management Card (NMC)

# Specifications

Refer to the APC Web site, [www.apc.com](http://www.apc.com), for detailed specifications.

## Environmental specifications

<b>CAUTION</b>	
<b>RISK OF EQUIPMENT DAMAGE</b>	
<ul style="list-style-type: none"> <li>• UPS must be used indoors only.</li> <li>• The installation location should be sturdy to withstand the weight of the UPS.</li> <li>• Do not operate UPS where there is excessive dust or where the temperature or humidity are outside specified limits.</li> </ul>	
<b>Failure to follow these instructions can result in equipment damage.</b>	

<b>Temperature</b>	<b>Operating</b>	0° to 40°C at full load 40° to 50°C linearly derated to 75% of UPS capacity
	<b>Storage</b>	-15° to 60°C
<b>Maximum elevation</b>	<b>Operating</b>	100% of UPS capacity up to 1000 m Linearly derate above 1000 m. 90% of UPS capacity at 3000 m (10,000ft)
	<b>Storage</b>	15,000 m (50,000 ft)
<b>Humidity</b>		0 to 95% relative humidity, non-condensing

## Physical specifications

The UPS is heavy. Follow all lifting guidelines.

<b>Dimensions without packaging Width x Height x Depth</b>	13.4 cm (5.3 in) x 43.3 cm (17 in) x 70.6 cm (27.8 in)	
<b>Dimensions with packaging Width x Height x Depth</b>	27.5 cm (10.8 in) x 57 cm (22.4 in) x 79 cm (31.1 in)	
<b>Weight</b>	27.5 kg	18 - 32 kg (40 - 70 lb) 
<b>Weight with packaging</b>	32 kg	

## Input specifications

	1 phase	3 phase + Neutral
<b>Nominal input voltage</b>	230 V	400 V
<b>Input frequency</b>	40 - 70 Hz	
<b>Input connection</b>	Hardwire	
<b>Input voltage range</b>	160 V - 285 V at 100% load UPS will be de-rated between 100 Vac to 160 Vac	277 V - 494 V at 100% load UPS will be de-rated between 173 Vac to 277 Vac
<b>Input power factor (100% load)</b>	0.98	

## Output specifications

<b>Output power capacity</b>	9000 W / 10000 VA
<b>Nominal output voltage</b>	230 V
<b>Other programmable voltages</b>	220/240 V
<b>Efficiency at full load</b>	> 94% in online mode > 98% in green mode
<b>Waveform</b>	Sinewave
<b>Output connection</b>	Hardwire

## Bypass specifications

<b>Bypass type</b>	Internal static bypass (automatic and manual), optional external bypass
<b>Bypass input voltage range</b>	170 - 270 V
<b>Max. bypass current</b>	70 A
<b>Input protection</b>	Circuit breaker

## Battery charger

<b>Supported battery types</b>	Sealed Maintenance Free (SMF) / Valve Regulated Lead Acid (VRLA) type, Flooded / tubular / vented type
<b>Battery bank voltage</b>	192 V
<b>Maximum power/current</b>	3000 W / 13 A

## Install Stabilizer Brackets

### **⚠ CAUTION**

#### **DAMAGE TO EQUIPMENT OR PERSONNEL**

UPS will topple if the stabilizer brackets are not installed and when the UPS is installed in the tower position.

**Failure to follow these instructions can result in equipment damage and personal injury.**

The UPS stabilizer brackets are packaged separately in the UPS box. Secure the stabilizer brackets to the bottom of the UPS with mounting screws (supplied).

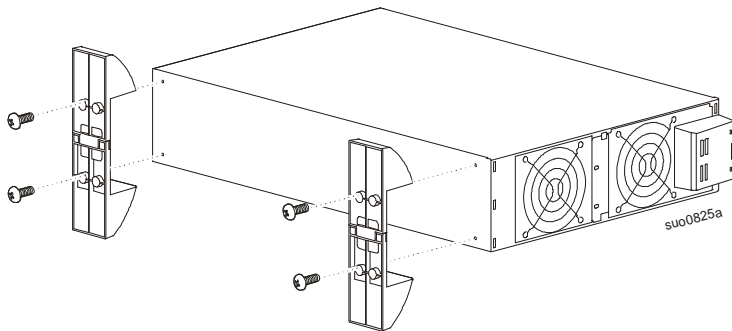

# Install Front Bezel

## CAUTION

### RISK OF EQUIPMENT DAMAGE

Do not operate the UPS without installing the front bezel.

**Failure to follow this instruction can result in equipment damage.**

The UPS front bezel is packaged separately in the UPS box. Unpack the bezel and hold it with the cutout section on top. Place the tab on the bottom of the bezel into the slot at the bottom of the UPS. Gently snap the top of the bezel into place. The bezel contains an air filter. The bezel can be removed by unsnapping the top, and then lifting the bezel up and out of the tab at the bottom of the UPS.

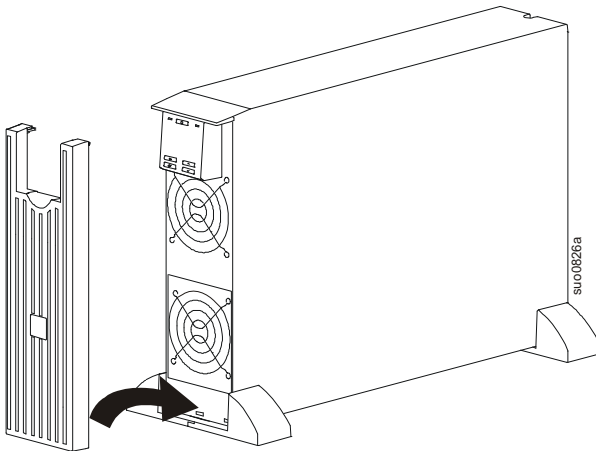

**Note:** The air filter, in the bezel, should be cleaned periodically. Remove the bezel from the UPS. Either use an air blower or use a vacuum pump to dry clean the air filter.

Contact APC by Schneider Electric customer support for detailed instructions on cleaning the air filter.



# Tower to Rack Mount Conversion

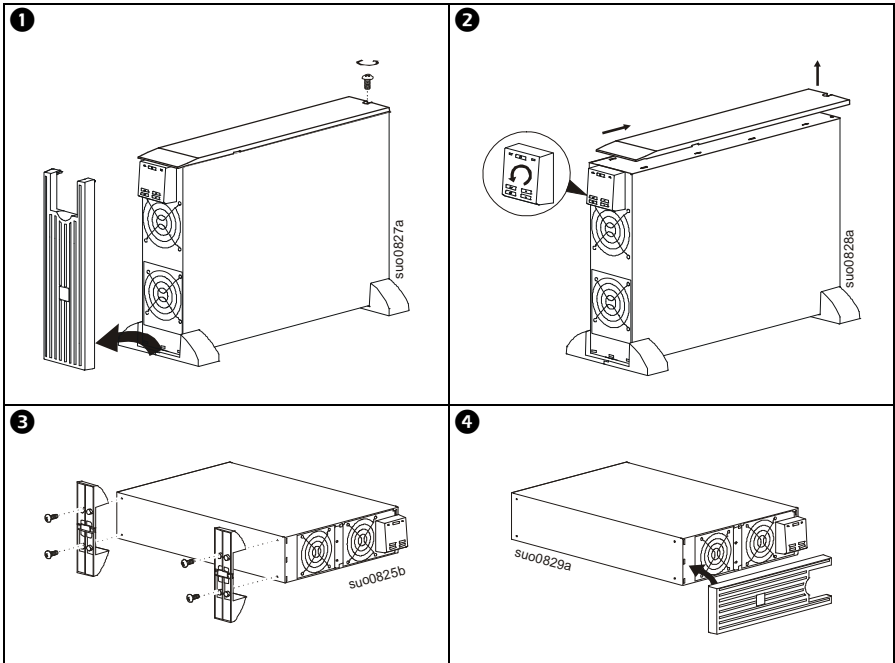

# Terminal Block Covers

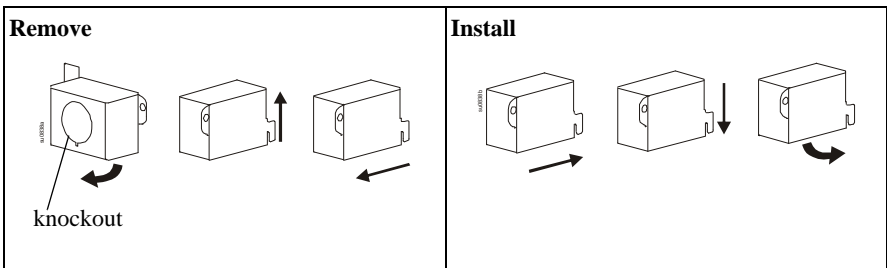
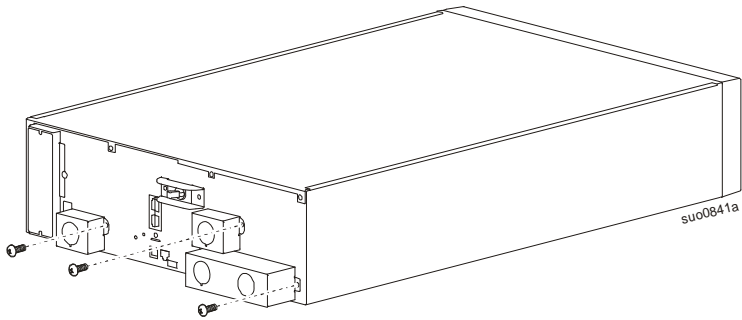

# Rear Panel Features

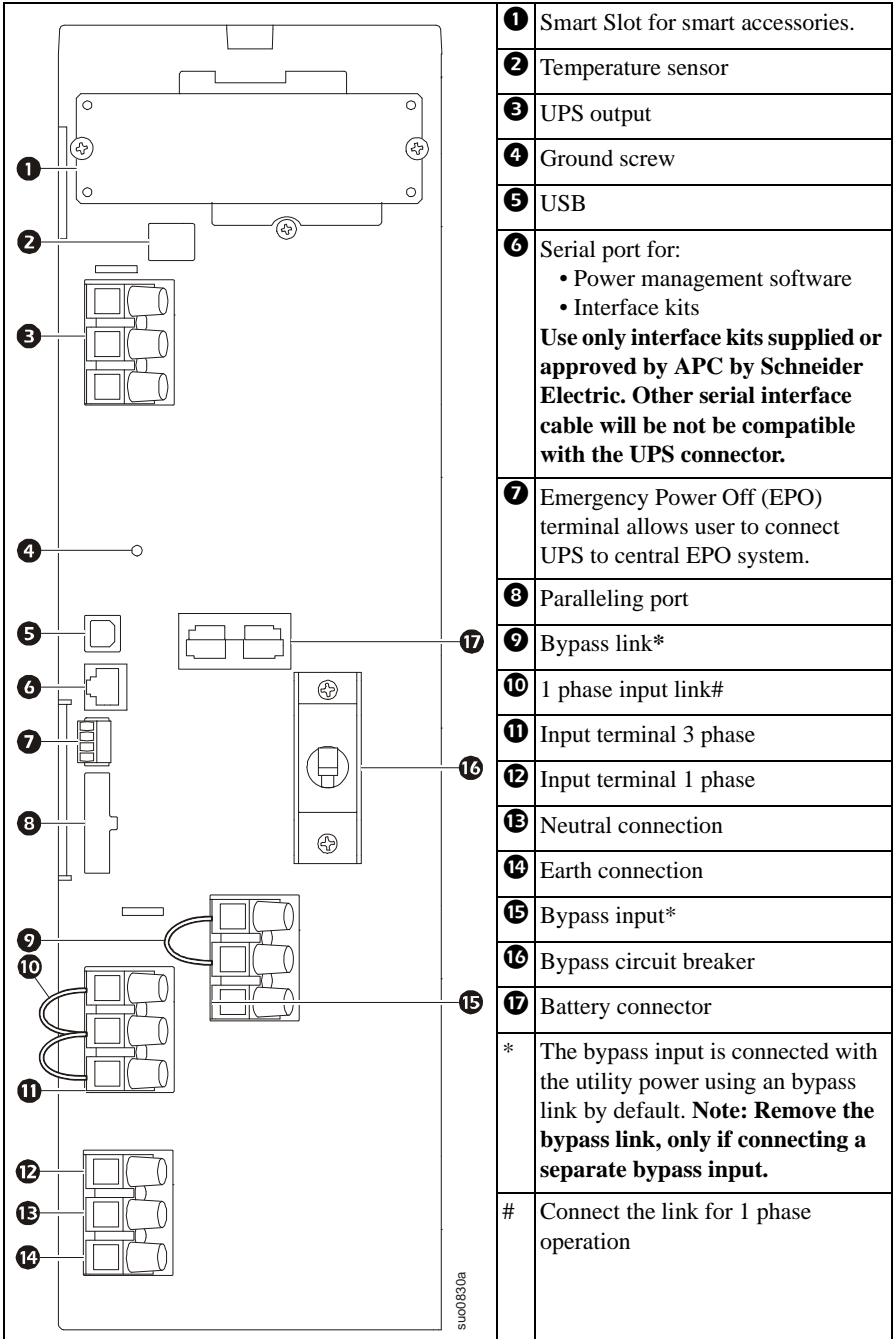

suco0830a

<b>1</b>	Smart Slot for smart accessories.
<b>2</b>	Temperature sensor
<b>3</b>	UPS output
<b>4</b>	Ground screw
<b>5</b>	USB
<b>6</b>	Serial port for: <ul style="list-style-type: none"> <li>• Power management software</li> <li>• Interface kits</li> </ul> <b>Use only interface kits supplied or approved by APC by Schneider Electric. Other serial interface cable will be not be compatible with the UPS connector.</b>
<b>7</b>	Emergency Power Off (EPO) terminal allows user to connect UPS to central EPO system.
<b>8</b>	Paralleling port
<b>9</b>	Bypass link*
<b>10</b>	1 phase input link#
<b>11</b>	Input terminal 3 phase
<b>12</b>	Input terminal 1 phase
<b>13</b>	Neutral connection
<b>14</b>	Earth connection
<b>15</b>	Bypass input*
<b>16</b>	Bypass circuit breaker
<b>17</b>	Battery connector
*	The bypass input is connected with the utility power using an bypass link by default. <b>Note: Remove the bypass link, only if connecting a separate bypass input.</b>
#	Connect the link for 1 phase operation

# Installation



Units may vary in appearance from those depicted in this manual.

See “Physical specifications” on page 5 in this manual before installing units.

## Output hardwire instructions

### ⚠ CAUTION

#### HAZARD OF ELECTRIC SHOCK

- All electrical work must be performed by a qualified electrician.
- Turn off all power to this equipment before working on the equipment. Practice lockout/tagout procedures.
- Do not wear jewelry when working with electrical equipment.
- Ensure that line, neutral and ground cables are connected to the respective terminals.
- Strain reliefs are not supplied with the unit. Use appropriate strain relief.
- All openings that allow access to UPS hardwire terminals must be covered.
- Select wire size and connectors according to national and local codes.

**Failure to follow these instructions can result in serious injury.**

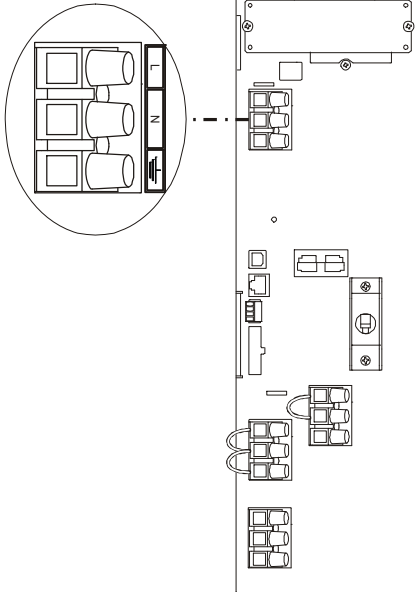

### Adhere to all national and local electrical codes.

- Use 10 mm<sup>2</sup> gauge wire (not supplied)
  - Maximum output rating:  
220-240 V, 50-60 Hz, 46 A
1. Locate the hardwire terminal block cover on rear panel of UPS. Remove the screw securing the cover and remove the cover.
  2. Remove the knockout from the cover.
  3. Connect the line, ground and neutral wires to the terminal block. Terminals are labelled for proper wire configuration.
  4. Replace and secure the cover removed in *step 1*.

## Input hardwire instructions

### CAUTION

#### HAZARD OF ELECTRIC SHOCK

- All electrical work must be performed by a qualified electrician.
- Adhere to all national and local electrical codes.
- Turn off all power to this equipment before working on the equipment. Practice lockout/tagout procedures.
- Do not wear jewelry when working with electrical equipment.
- Verify the ground connection is secured.
- Leakage current for a pluggable Type B or permanently connected UPS may exceed 3.5 mA. Separate ground terminal must be used.
- Ensure that line, neutral and ground cables are connected to the respective terminals.
- Strain reliefs are not supplied with the unit. Use appropriate strain relief.
- All openings that allow access to UPS hardwire terminals must be covered.
- Select wire size and connectors according to national and local codes.

**Failure to follow these instructions can result in serious injury.**

Input Configuration	Current Max. (full load)	External Circuit Breaker	Wire Gauge (typical)	1 phase input link
1 phase	81 A	100 A / 2 pole	10 mm <sup>2</sup>	Connect
3 phase + Neutral	28 A / phase when UPS is in <b>online</b> mode. 70 A on L2 when UPS is in <b>bypass</b> mode.	100 A / 4 pole	<b>Note:</b> Use 105°C temperature rated cable.	Do not connect

1. Switch the external circuit breaker off.
2. Locate the hardwire terminal block on rear panel of UPS. Remove the screw securing the cover and remove the cover.
3. Remove the knockout from the supplied input terminal block cover.
4. Connect the line, ground and neutral wires to the terminal block. Terminals are labelled for proper wire configuration.
  - a. Connect the 1 phase input link for single phase operation.
  - b. Do not connect the 1 phase input link for 3 phase operation.
5. Secure the input terminal block cover with screw.

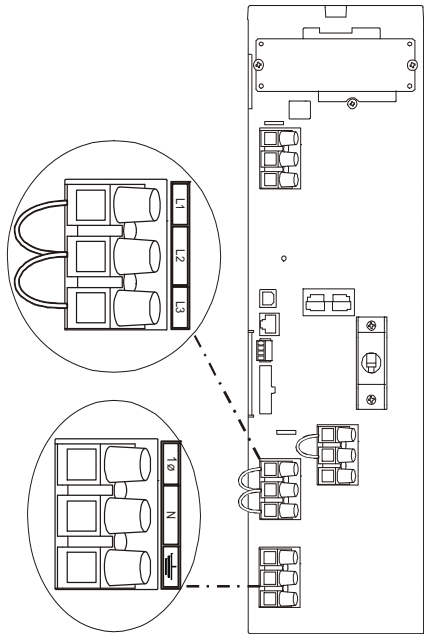

su00832a

## Optional bypass input hardwire instructions

### ⚠ CAUTION

#### HAZARD OF ELECTRIC SHOCK

- All electrical work must be performed by a qualified electrician.
- Turn off all power to this equipment before working on the equipment. Practice lockout/tagout procedures.
- Do not wear jewelry when working with electrical equipment.
- Ensure that line, neutral and ground cables are connected to the respective terminals.
- Strain reliefs are not supplied with the unit. Use appropriate strain relief.
- All openings that allow access to UPS hardwire terminals must be covered.
- Select wire size and connectors according to national and local codes.

**Failure to follow these instructions can result in serious injury.**

#### Adhere to all national and local electrical codes.

- Use 10 mm<sup>2</sup> gauge wire (not supplied)
1. Locate the hardwire terminal block cover on rear panel of UPS. Remove the screw securing the cover and remove the cover.
  2. Remove the knockout from the cover.
  3. Remove the bypass link.
  4. Connect the line and neutral wires to the terminal block. Terminals are labelled for proper wire configuration.  
**Note:** Do not connect any wire to the **Utility** terminal.
  5. Replace and secure the cover removed in *step 1*.

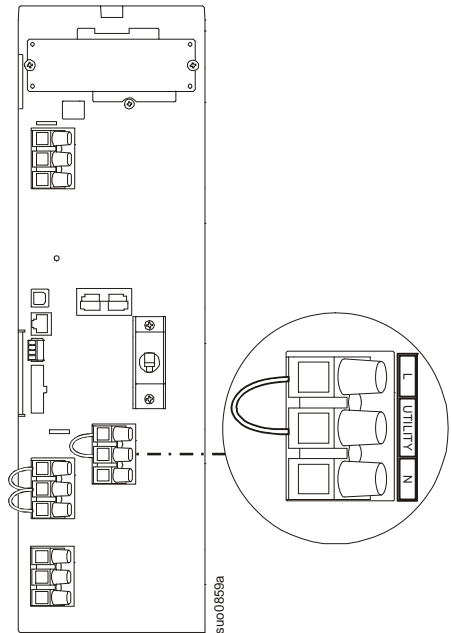

# Connect the UPS to a Battery System

## ⚠ CAUTION

### HAZARD OF ELECTRIC SHOCK

- Adhere to all national and local electrical codes.
- All electrical work must be performed by a qualified electrician.
- Identify the polarities of the battery terminals before connecting the battery series.
- Do not short the battery terminals.
- Do not touch multiple terminals in the battery strings at the same time.
- Do not wear jewelry when working with electrical equipment.

**Failure to follow these instructions can result in serious injury.**

1. Use the supplied battery connection cable. Connect the positive (red) and negative (black) wires, to the positive and negative terminals respectively, on each external battery string.
2. Connect a 6 mm<sup>2</sup> ground wire (not supplied), to the battery enclosure ground and the ground screw on the back of the UPS.
3. Plug the external battery cable connector into the external battery connector receptacle on the rear side of the UPS.
4. Each string of sixteen 12 V batteries must have a 100-120 A fuse or circuit breaker of appropriate voltage rating installed.



Fuse: 

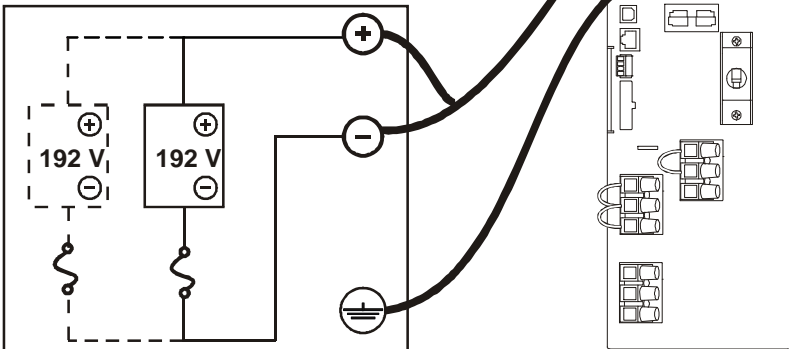

su00633a

# Start Up

## Connect equipment, external batteries and input power to the UPS

### CAUTION

#### HAZARD OF ELECTRIC SHOCK

- All electrical work must be performed by a qualified electrician.
- Turn off all power to this equipment before working on the equipment.
- Practice lockout/tagout procedures.
- Do not wear jewelry when working with electrical equipment.

**Failure to follow these instructions can result in serious injury.**

1. Connect equipment to UPS (cables not supplied). See “Output hardware instructions” on page 11 in this manual.
2. Connect external batteries to UPS. See “Connect the UPS to a Battery System” on page 15 in this manual.
3. Connect input utility power to the UPS.
4. Switch the utility input magnetic circuit breaker and the bypass circuit breaker on. The display panel will illuminate when utility power is available. Wait till the UPS initialization is complete.

## Start the UPS

Press and hold the POWER ON/OFF button located on the front panel of UPS until a short beep is heard to start the UPS. See “Front display panel features” on page 18 in this manual.

## Cold start the UPS

Use cold start feature to supply power to connected equipment from the UPS batteries.

Press the POWER ON/OFF button. The display panel will illuminate. Wait till the UPS initialization is complete.

Press and hold the POWER ON/OFF button again, until a short beep is heard, to supply battery power to the connected equipment.

## Install PowerChute™ software

To install PowerChute Business Edition (PCBE) software, connect the supplied serial communication cable to the serial port on the UPS and the other end to a computer with access to the Web.

On the computer, go to [www.apc.com/tools/download](http://www.apc.com/tools/download). Select **Software Upgrades - PowerChute Business Edition** in the **Filter by Software/Firmware** drop down menu. Select the appropriate operating system. Follow directions to download the software.



# Product Registration

Register the UPS with APC by Schneider Electric customer support. This is a one time process done during installation. The UPS can be only operated for a trial run period of 24 hours if the registration is not complete. The display screen will prompt for registration when the UPS is started after installation. See “Front display panel features” on page 18 for button information.

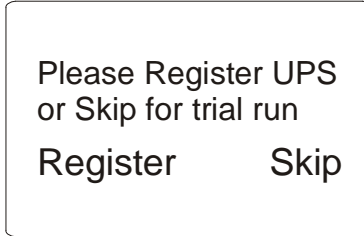

1. Press the UP/DOWN ARROW buttons to select between Register and Skip options.
2. Press ENTER button after the required option is selected.
3. Register option will navigate into the password prompt screen.

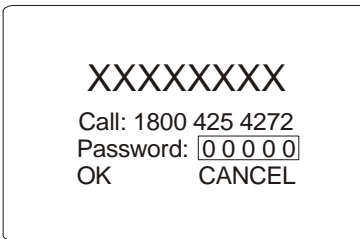

4. Select cancel and press ENTER button to go back to the previous screen.
5. Call 18004254272 or 18001030011 to get the 5 digit password.
6. Press the UP/DOWN ARROW buttons to select the password

numbers.

7. Press the ENTER button to select the next password digit and MUTE/ESC button to select the previous password digit.
8. Press the ENTER button to select the OK option, when 5 digit password is entered.
9. After password verification, UPS will navigate to Home screen and continue the normal operation.
  - Selecting Skip option allows the UPS to run for limited period of time. After this trial run period, UPS will drop the load and prompt for UPS registration again.
  - Retry password is allowed only for 3 times. After three attempts, the UPS will be inoperable until the next power cycle.

**Note: UPS registration screen is shown only if this feature is enabled in the factory configuration.**

**Note: If the UPS is shut down before entering the password, the customer should obtain a new password from the customer support.**

# Operation



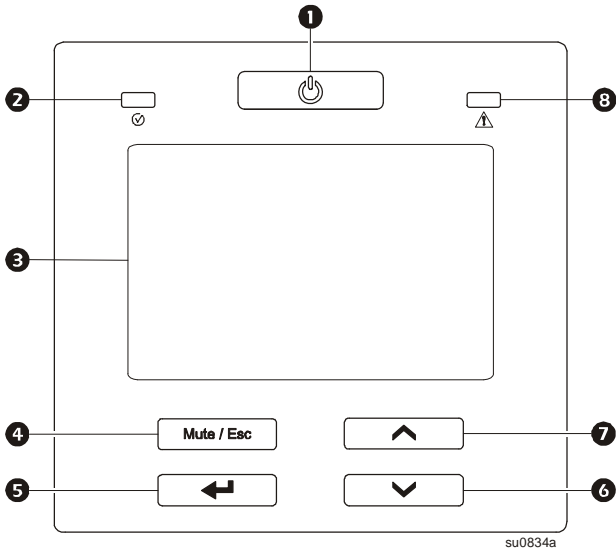





## Front display panel features



1	<b>POWER ON/OFF button</b>	<p>Press the POWER ON/OFF button to</p> <ul style="list-style-type: none"> <li>• Turn on the UPS in battery mode when utility power is not available.</li> <li>• Turn the output of the UPS on. Press and hold the button until a short beep is heard.</li> <li>• Turn the output of the UPS off. Press and hold the button until a short beep is heard.</li> </ul>
2	<b>Online / On battery status LED</b>	<ul style="list-style-type: none"> <li>• The <b>Online / On battery status LED</b> illuminates green when the UPS is in <b>online</b> mode and illuminates amber when the UPS is in the <b>on battery</b> mode.</li> <li>• UPS is in Standby condition connected to utility power - Green LED will blink continuously.</li> <li>• UPS is in Standby condition with only Battery connected - Amber LED will blink continuously</li> </ul>
3	<b>LCD Display</b>	The display interface options are visible on the LCD screen.
4	<b>MUTE/ESC button</b>	<ul style="list-style-type: none"> <li>• Press the MUTE/ESC button to go to the previous menu.</li> <li>• Press this button to temporarily mute the alarms.</li> </ul>
5	<b>ENTER button</b>	Press the ENTER button to enter in to the menu or to select a menu item/value during navigation.
6	<b>DOWN ARROW button</b>	Press the DOWN ARROW button to scroll through the main menu options and display screens. Use this button to decrement numeric values.
7	<b>UP ARROW button</b>	Press the UP ARROW button to scroll through the main menu options and display screens. Use this button to increment numeric values.

8	<b>Fault/Error /Alert detection LED</b>	The UPS detects an internal fault. <b>Alert detected</b> - LED will blink continuously. <b>Fault / Error detected</b> - LED will illuminate continuously. See “Troubleshooting” on page 28 in this manual.
---	---	---

## Front display icons

	<b>Online:</b> The UPS is drawing utility power and performing double conversion to supply power to the connected equipment.
	<b>On Battery:</b> The UPS is supplying battery backup power to the connected equipment.
	<b>Bypass:</b> The UPS is in <b>bypass</b> mode, sending utility power directly to connected equipment. <b>Bypass</b> mode operation is the result of an internal UPS fault detection, an overload condition, or a user initiated command or through an accessory. Battery backup power is not available while the UPS is in <b>bypass</b> mode.
	<b>System Error:</b> An internal fault/error/alert is detected. This icon is also displayed when Emergency Power Off (EPO) is active.
	<b>Check Battery:</b> The battery may be near the end of its service life.
	<b>Battery Charge:</b> The battery charge level is indicated by the number of bar sections illuminated. When all five blocks are illuminated, the battery is charged to capacity. Each bar represents approximately 20% of the battery charge capacity.
	<b>Load Level:</b> The load percentage is indicated by the number of load bar sections illuminated. Each bar represents approximately 20% of the load.
	<b>Green Mode:</b> An illuminated icon indicates that the unit is working in <b>Green</b> mode. The connected equipment is receiving the utility input directly as long as the input voltage and frequency are within the configured limits.

## Status Indicators

Audible Alarm	Condition
2 short beeps every 5 second	<b>Low runtime</b> - The battery is nearing low state of charge. The UPS is about to shutdown.
	<b>Low battery state</b> - UPS has shutdown due to the low state of charge of the battery.
	<b>Battery disconnect</b> - The battery is disconnected.
	<b>Alert state</b> - The UPS has indicated an alert.
4 beeps every 30 sec	<b>On battery state</b> - The UPS is supplying battery backup power to the connected equipment.
Beeper continuously on	<b>Fault/Error detected</b> - The UPS has detected a fault/error.
	<b>Overload condition</b> - The equipment connected to the UPS is drawing more power than rated.
	<b>Failure Bypass state</b> - The UPS has detected a fault. Connected equipment receives utility input power through the bypass.

## User Interface Menu Structure

Menu	Sub menu	Parameters
Status	View UPS Information	<ul style="list-style-type: none"> <li>• UPS self test results</li> <li>• UPS installation date</li> </ul>
	View Output Information	<ul style="list-style-type: none"> <li>• Output status</li> <li>• Output voltage, frequency and current</li> <li>• Output Power: Real and apparent</li> </ul>
	View Input Information	<ul style="list-style-type: none"> <li>• Phase1: voltage and Frequency</li> <li>• Phase2: voltage and Frequency</li> <li>• Phase3: voltage and Frequency</li> <li>• Bypass: voltage and Frequency</li> </ul>
	View Battery Information	<ul style="list-style-type: none"> <li>• State of charge percentage</li> <li>• Battery voltage and current</li> <li>• Battery runtime remaining</li> <li>• Battery installation date</li> </ul>

<b>Menu</b>	<b>Sub menu</b>	<b>Parameters</b>
Output	UPS Control	<ul style="list-style-type: none"> <li>• UPS off (Shows when output is off and bypass input is bad)</li> <li>• Clear fault</li> </ul>
	Output Control	<ul style="list-style-type: none"> <li>• Cancel outlet command</li> <li>• Turn off output: Show when output is On</li> <li>• Turn on output: Show when output is Off</li> <li>• Output into bypass: The bypass mode is enabled</li> <li>• Output out off bypass: The bypass mode is disabled</li> </ul>
Configuration	UPS Settings	<ul style="list-style-type: none"> <li>• UPS output voltage</li> <li>• Green mode settings</li> <li>• Menu type</li> <li>• Low runtime</li> <li>• Bypass settings</li> <li>• Auto self test</li> <li>• Firmware update</li> <li>• Restore defaults</li> <li>• UPS installation date</li> </ul>
	Battery Settings	<ul style="list-style-type: none"> <li>• Type of Battery</li> <li>• Battery Ah selection</li> <li>• Charge rate percentage (when SMF battery is configured)</li> <li>• Battery installation date</li> </ul>
	Display Settings	<ul style="list-style-type: none"> <li>• Beeper volume intensity</li> <li>• Backlight intensity</li> <li>• Backlight timeout</li> <li>• Battery beep enable</li> </ul>
	Date and Time Settings	<ul style="list-style-type: none"> <li>• Seconds</li> <li>• Minutes</li> <li>• Hours</li> <li>• Days</li> <li>• Months</li> <li>• Years</li> </ul>
	NMC information (Option available when NMC is connected)	<ul style="list-style-type: none"> <li>• IP mode</li> <li>• IP address (Shows when IP mode is manual)</li> <li>• Subnet mask (Shows when IP mode is manual)</li> <li>• Gateway (Shows when IP mode is manual)</li> </ul>

Menu	Sub menu	Parameters
Logs	Faults	<ul style="list-style-type: none"> <li>• View last 10 faults occurred in the UPS</li> </ul>
	Service Logs	<ul style="list-style-type: none"> <li>• View last 2 events occurred in the UPS</li> </ul>
About	View UPS Information	<ul style="list-style-type: none"> <li>• View model number</li> <li>• DSP application version</li> <li>• DSP Boot loader version</li> <li>• Communications application version</li> <li>• Communications Boot loader version</li> </ul>
	NMC information (Option available when NMC is connected)	<ul style="list-style-type: none"> <li>• NMC model number</li> <li>• NMC serial number</li> <li>• NMC hardware version</li> <li>• NMC firmware version</li> <li>• NMC OS version</li> <li>• NMC bootloader version</li> <li>• NMC Mac address</li> <li>• NMC IP address</li> <li>• NMC subnet mask</li> <li>• NMC default gateway</li> </ul>

## Configuration

### UPS settings

Configure UPS settings using the display interface or by using the PowerChute software.

Function	Factory Default	User Selectable Options	Description
<b>Output voltage</b>	230 Vac	220 Vac 230 Vac 240 Vac	Allows the user to select output voltage.
<b>Green mode</b>	Disable	Enable Disable	Connected equipment receives power from the bypass line, as long as specified voltage limits are available.
<b>Green low transfer point</b>	195 Vac	195-225 Vac	Lower voltage limit of the UPS in the bypass line to operate in green mode.
<b>Green high transfer point</b>	255 Vac	235-255 Vac	Upper voltage limit of the UPS in the bypass line to operate in <b>Green</b> mode.

Function	Factory Default	User Selectable Options	Description
<b>Low runtime</b>	600 sec	0 - 65535 sec	UPS will indicate an alarm when the battery has reached the configured runtime limit.
<b>Bypass low transfer point</b>	170 Vac	170 - 220 Vac	The minimum voltage after which the UPS will supply power to the connected equipment in the bypass mode.
<b>Bypass high transfer point</b>	270 Vac	240 - 270 Vac	The maximum voltage after which the UPS will supply power to the connected equipment in the bypass mode.
<b>Auto self test</b>	At Startup and once every 7 days thereafter	<ul style="list-style-type: none"> <li>• At Startup and once every 14 days thereafter</li> <li>• At Startup and once every 7 days thereafter</li> <li>• Only at startup</li> <li>• Never</li> <li>• Start now</li> </ul>	Allows the user to set the interval for the UPS to perform self test.
<b>Reset factory defaults</b>	No	Yes No	Select Yes to set all the user configurable settings to factory default.

## Battery settings

Function	Factory Default	User Selectable Options	Description
<b>Battery type connected</b>	SMF	SMF, Flooded/Tubular	Allows user to select type of battery. SF: Sealed Maintenance Free/VRLA Fld: Flooded/Tubular/Vented <b>Note:</b> The UPS charging profile changes according to the battery selection.
<b>Total battery Ah capacity connected</b>	42 Ah	7 - 200 Ah	Allows user to set total Ah of the batteries connected to the UPS. See “External Batteries” on page 27 in this manual. The battery charging current limit changes based on this setting.
<b>Charge rate percentage</b>	200%	100 - 300% (incremented in steps of 10)	Allows the user to change the charge rate. Applicable when SMF battery is configured.

## Display settings

Configure the display parameters from the LCD interface.

Function	Factory Default	User Selectable Options	Description
<b>Beeper volume index</b>	Loudest	Soft Loud Loudest	Allows the user to set beeper volume level.
<b>Backlight intensity</b>	High	Low Medium High	Allows the user to set backlight intensity level.
<b>Backlight time out</b>	60 sec	5 - 300 sec (increased in steps of 1)	Allows user to select the time duration for the display backlight to turn off. The backlight will turn on when any key is pressed or when the UPS detects any error/alert.
<b>On battery beeps</b>	Enable	Enable Disable	Allows user to mute/unmute the UPS for on battery beeps.

## Date and time settings

Configure the date and time of the UPS.

Function	Factory Default	User Selectable Options	Description
<b>Second</b>	NA	00 - 59 (incremented in steps of 1)	Allows the user to set real time clock of UPS.
<b>Minute</b>	NA	00 - 59 (incremented in steps of 1)	Allows the user to set real time clock of UPS.
<b>Hour</b>	NA	00-23 (incremented in steps of 1)	Allows the user to set real time clock of UPS.
<b>Day</b>	NA	00 - 31 (incremented in steps of 1)	Allows the user to set real time clock of UPS.
<b>Month</b>	NA	01 - 12 (incremented in steps of 1)	Allows the user to set real time clock of UPS.
<b>Year</b>	NA	00 - 99 (incremented in steps of 1)	Allows the user to set real time clock of UPS.



## Configure UPS parameters

Follow the steps to configure parameters in the UPS:

1. Press the **ENTER** button.
2. Press the **UP/DOWN ARROW** buttons to navigate to configurations.
3. Press the **ENTER** button to select appropriate settings.
4. Press the **UP/DOWN ARROW** buttons to navigate to appropriate settings.
5. Press the **ENTER** button to select appropriate settings.
6. Navigate through the parameters using the **UP/DOWN ARROW** buttons.
7. Press the **ENTER** button to edit a parameter. Icons start flashing to indicate the editing.
8. Press the **UP/DOWN ARROW** buttons to navigate between the options available for the selected parameter.
9. Press the **ENTER** button to select the option or **MUTE/ESC** button to abort the editing of current parameter. Flashing of icons stops after this.
10. Press the **UP/DOWN ARROW** buttons to navigate between parameters.
11. Press the **MUTE/ESC** button to exit menu navigation.

## Emergency Power Off

### Overview

The Emergency Power Off (EPO) option is a feature that will immediately disconnect all connected equipment from the UPS. The UPS will immediately shut down and will not switch to battery power.

Adhere to all national and local electrical codes. Wiring must be performed by a qualified electrician.

Connect each UPS to the EPO switch. In configurations where multiple units are connected in parallel, each UPS must be connected to the EPO switch.

The UPS must be restarted for power to return to connected equipment. Press the **ON/OFF** button on the front panel of the UPS. Press the **ESCAPE** button followed by the **ENTER** button to go to main menu. Navigate to control menu and clear the faults.

## Normally open contacts

1. If the EPO switch or relay contacts are normally open, insert the wires from the switch or contacts at pins 1 and 2 of the EPO terminal block. Use 1.3 - 0.8 mm<sup>2</sup> (16-28 AWG) wire.
2. Secure the wires by tightening the screws.
3. If the contacts are closed, the UPS will turn off and power will be removed from the load.

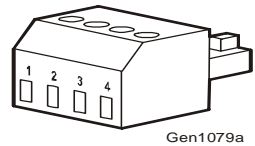

## Normally closed contacts

1. If the EPO switch or relay contacts are normally closed, insert the wires from the switch or contacts at pins 2 and 3 of the EPO terminal block. Use 1.3 - 0.8 mm<sup>2</sup> (16-28 AWG) wire.
2. Insert a wire jumper between pins 1 and 2. Secure the wires by tightening the three screws at positions 1, 2, and 3.
3. If the contacts are opened, the UPS will turn off and power will be removed from the load.

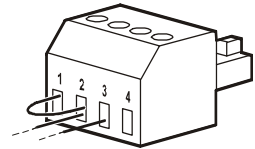

**Note:** Pin 1 is the power source for the EPO circuit, it provides a few milliampere of 24 V power.

If the normally closed (NC) EPO configuration is used, the EPO switch or relay should be rated for “dry” circuit applications, the rating should be for low voltage and low current applications. This normally implies the contacts are gold-plated.

The EPO interface is a Safety Extra Low Voltage (SELV) circuit. Connect the EPO interface only to other SELV circuits. The EPO interface monitors circuits that have no determined voltage potential. SELV circuits are controlled by a switch or relay properly isolated from utility power. To avoid damage to the UPS, do not connect the EPO interface to any circuit other than a SELV circuit.

## External Batteries

### CAUTION

#### EQUIPMENT DAMAGE

- Do not connect a battery string with voltage greater than 192 VDC.
- Ensure the type and Ah of the battery is configured correctly.

**Failure to follow these instructions can result in equipment damage.**

Use SMF or tubular/flooded type batteries for optimum battery charger performance.

The external battery system equals sixteen 12 V batteries connected in series.

**Refer to the APC Web site, [www.apc.com](http://www.apc.com) or an APC by Schneider Electric dealer for information regarding APC by Schneider Electric external battery solutions.**

See “Configuration” on page 22 in this manual for details on battery string configuration.

The battery charger operates at a constant current / constant voltage charging mode. The internal battery charger is rated 3000 Watt. maximum.

Actual maximum charging current depends on the total Ah and type of the battery configured on the UPS.

Configure the battery Ah in UPS settings. Compute the total Ah of the battery string (or strings) connected and configure.

**Note: For batteries above 120 Ah SMF and 150 Ah tubular/flooded an external charger is recommended.**

# Troubleshooting

Problem and/or Possible Cause	Solution
<b>UPS will not turn on when utility input power is available or there is no power output</b>	
The UPS is not turned on.	Press and hold the POWER ON/OFF button until a short beep is heard to turn on the UPS.
The UPS is not connected to utility power supply.	Check that the power cable from the UPS to the utility power supply is securely connected at both ends. See “Start Up” on page 16 in this manual.
Bypass input thermal circuit breaker on the UPS is tripped.	Turn on the bypass input circuit breaker.
No input voltage in the bypass terminal.	Install shorting link or provide bypass input.
<b>UPS, when connected to battery, is not supplying power to the connected equipment</b>	
The UPS is not turned on.	If the UPS has shutdown (the display is not on), follow the “Cold start the UPS” on page 16 procedure in this manual.
The battery is not connected.	Connect battery to the UPS. See “Connect the UPS to a Battery System” on page 15 in this manual.
Low battery cut off. UPS may have discharged the battery due to utility power outage and turned the output off due to low battery condition.	Wait for the utility power to return and charge the battery. To turn on the output power after utility power returns, press POWER ON/OFF button.
<b>The UPS is operating on battery, while connected to the input utility power</b>	
There is high, low, or distorted input voltage or frequency.	Connect the UPS to a different outlet on a different circuit. Test the utility input power to ensure the unit is receiving input power. If display is on, navigate and check the input voltage and frequency.
<b>UPS emits an audible beep sound at long intervals</b>	
The UPS is operating normally when running on battery.	The UPS is operating on battery. See the status of the UPS in the display panel.

Problem and/or Possible Cause	Solution
<b>UPS is not providing expected backup time</b>	
The UPS battery is weak due to a recent power outage.	The batteries require recharging after extended outages. Batteries can wear faster when put into service often or when operated at elevated temperatures.
The battery is near the end of its service life.	If the battery is near the end of its service life, consider replacing the battery, even if the replace battery indicator is not illuminated. See “Connect the UPS to a Battery System” on page 15 in this manual.
<b>Fault / Alert LED is illuminated. The UPS displays a fault message and emits a constant beeping sound</b>	
The UPS has detected an internal fault.	Contact APC by Schneider Electric customer support.
<b>No audible sounds from UPS even when the UPS is in on battery status</b>	
Audible alarm is disabled.	Change the UPS configuration to enable audible alarms. See “Display settings” on page 24 in this manual.
<b>UPS is not turning off</b>	
Utility input power is available.	UPS logic power can not be turned off if utility input power is available. To turn off the UPS, turn off utility input power. Go to Control > UPS Control > UPS off.
<b>UPS is in Bypass mode and the LED is not illuminated red</b>	
UPS is in green mode.	Disable green mode if not desired.
UPS is configured to stay in the bypass mode.	Change the configuration to exit bypass mode.

Problem and/or Possible Cause	Solution
<b>UPS is in Bypass mode and the LED is illuminated red</b>	
The UPS has experienced an overload condition and transferred to bypass.	<p>Connected equipment exceeds the “maximum load” as defined in specifications on the APC Web site, <a href="http://www.apc.com">www.apc.com</a>.</p> <p>The alarm remains on until the overload condition is corrected. Disconnect nonessential equipment from the UPS to avoid the overload condition.</p> <p>The UPS continues to supply power as long as it is in bypass mode and the bypass circuit breaker does not trip. The UPS will not provide battery power in the event of a utility voltage interruption.</p>
UPS detected an internal fault and transferred to bypass.	Contact APC by Schneider Electric customer support.
<b>Green mode is enabled in UPS and the green mode icon is not illuminated</b>	
UPS is not working in Green mode	Allow the UPS to run for 24 hours. UPS will switch to Green mode only once in 24 hours when enabled.

## Service

If the unit requires service, do not return it to the dealer. Follow these steps:

1. Review the *Troubleshooting* section of the manual to eliminate common problems.
2. If the problem persists, contact APC by Schneider Electric Customer Support.
  - a. Note the model number and serial number and the date of purchase. The model and serial numbers are located on the rear panel of the unit and are available through the LCD display on select models.
  - b. Call APC by Schneider Electric Customer Support and a technician will attempt to solve the problem over the phone. If this is not possible, the technician will issue a Service Request Number.
  - c. If the unit is under warranty, the repairs are free.

An Authorised Service Representative will visit your location and try to resolve the issue.

# APC by Schneider Electric Customer Support India

Internet	<a href="http://www.apc.com/support">http://www.apc.com/support</a>
Toll Free BSNL network	1 800 425 4272
All other networks	city code + 39022272
E-mail	indiainfo@apc.com

## Limited Factory Warranty

Schneider Electric IT Business India Private Ltd. (SEITBIPL), warrants its products to be free from defects in materials and workmanship for a period of one (1) year from the date of purchase. The SEITBIPL obligation under this warranty is limited to repairing or replacing, at its own sole option, any such defective products or parts thereof. Repair or replacement of a defective product or part thereof does not extend the original warranty period.

This warranty applies only to the original purchaser who must have properly registered the product within 10 days of purchase. Products may be registered online at [warranty.apc.com](http://warranty.apc.com) or by mailing in the completed warranty registration card that is included with the documentation.

SEITBIPL shall not be liable under the warranty if its testing and examination disclose that the alleged defect in the product does not exist or was caused by end user or any third person misuse, negligence, improper installation, testing, operation or use of the product contrary to SEITBIPL recommendations or specifications. Further, SEITBIPL shall not be liable for defects resulting from: 1) unauthorized attempts to repair or modify the product, 2) incorrect or inadequate electrical voltage or connection, 3) inappropriate on site operation conditions, 4) Acts of God, 5) exposure to the elements, 6) theft. In no event shall SEITBIPL have any liability under this warranty for any product where the serial number has been altered, defaced, or removed, 7) normal wear resulting from frequent use.

**EXCEPT AS SET FORTH ABOVE, THERE ARE NO WARRANTIES, EXPRESS OR IMPLIED, BY OPERATION OF LAW OR OTHERWISE, APPLICABLE TO PRODUCTS SOLD, SERVICED OR FURNISHED UNDER THIS AGREEMENT OR IN CONNECTION HEREWITH.**

**SEITBIPL DISCLAIMS ALL IMPLIED WARRANTIES OF MERCHANTABILITY, SATISFACTION AND FITNESS FOR A PARTICULAR PURPOSE.**

**SEITBIPL EXPRESS WARRANTIES WILL NOT BE ENLARGED, DIMINISHED, OR AFFECTED BY AND NO OBLIGATION OR LIABILITY WILL ARISE OUT OF, SEITBIPL RENDERING OF TECHNICAL OR OTHER ADVICE OR SERVICE IN CONNECTION WITH THE PRODUCTS.**

**THE FOREGOING WARRANTIES AND REMEDIES ARE EXCLUSIVE AND IN LIEU OF ALL OTHER WARRANTIES AND REMEDIES. THE WARRANTIES SET FORTH ABOVE CONSTITUTE SEITBIPL'S SOLE LIABILITY AND PURCHASER'S EXCLUSIVE REMEDY FOR ANY BREACH OF SUCH WARRANTIES. SEITBIPL WARRANTIES EXTEND ONLY TO ORIGINAL PURCHASER AND ARE NOT EXTENDED TO ANY THIRD PARTIES.**

**IN NO EVENT SHALL SEITBIPL, ITS OFFICERS, DIRECTORS, AFFILIATES OR EMPLOYEES BE LIABLE FOR ANY FORM OF INDIRECT, SPECIAL, CONSEQUENTIAL OR PUNITIVE DAMAGES, ARISING OUT OF THE USE, SERVICE OR INSTALLATION OF THE PRODUCTS, WHETHER SUCH DAMAGES ARISE IN CONTRACT OR TORT, IRRESPECTIVE OF FAULT, NEGLIGENCE OR STRICT LIABILITY OR WHETHER SEITBIPL HAS BEEN ADVISED IN ADVANCE OF THE POSSIBILITY OF SUCH DAMAGES. SPECIFICALLY, SEITBIPL IS NOT LIABLE FOR ANY COSTS, SUCH AS LOST PROFITS OR REVENUE, WHETHER DIRECT OR INDIRECT, LOSS OF EQUIPMENT, LOSS OF USE OF EQUIPMENT, LOSS OF SOFTWARE, LOSS OF DATA, COSTS OF SUBSTITUANTS, CLAIMS BY THIRD PARTIES, OR OTHERWISE.**

To obtain service under warranty you must call customer support. Customers with warranty claims issues may access the SEITBIPL worldwide customer support network through the SEITBIPL Web site: [support.apc.com](http://support.apc.com). Select your country from the country selection drop down menu. Open the Support tab at the top of the web page to obtain information for customer support in your region. Refer to the product user manual for more information on how to contact customer support.