



by Schneider Electric

# Installation and Operation Guide

## Back-UPS™ BE700Y-IND/BE800-IND

### Inventory

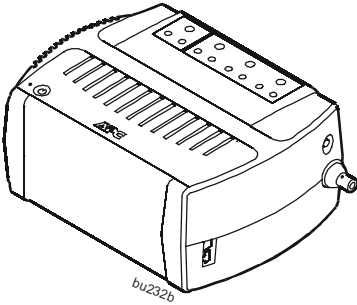

BE700Y-IND only

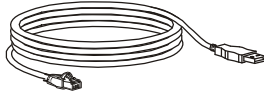

### Safety and General Information

This unit is intended for indoor use only.

Do not operate this unit in direct sunlight, in contact with fluids, or where there is excessive dust or humidity.

Be sure the air vents on the UPS are not blocked.

Allow adequate space for proper ventilation.

The battery typically lasts for two to five years. Environmental factors impact battery life. Elevated ambient temperatures, poor quality utility power, and frequent short duration discharges will shorten battery life.

Connect the Back-UPS power cable directly to a wall outlet. Do not use surge protectors or extension cords.

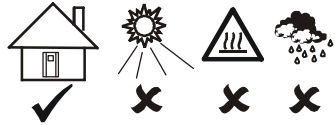

# Installation

## Connect equipment to the outlets and to the network ports

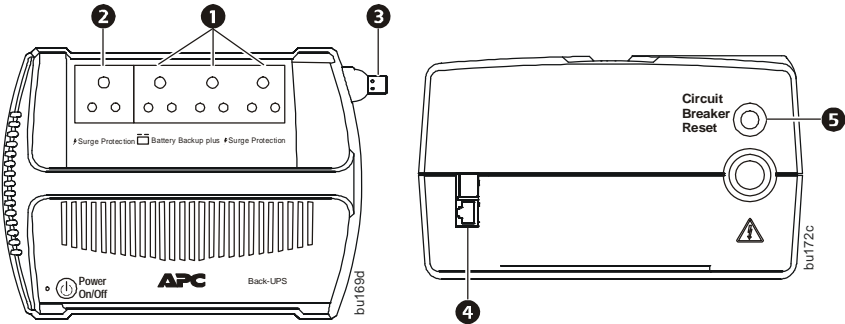

<p><b>1</b></p>	<p><b>Battery Backup plus Surge Protection outlets</b></p>	<p>These outlets provide battery backup power to connected equipment for a limited period of time during power outages and voltage fluctuations.</p> <p>The <b>Battery Backup</b> outlets provide battery power to connected equipment only when the Back-UPS is turned on. Connect critical equipment such as desktop computer, computer monitor, modem or other data sensitive devices to these outlets. Do not connect aquarium equipment, laser printers, paper shredders, sump pumps, or fans to these outlets as the modified sine wave output of the Back-UPS may cause these devices to experience a decrease in performance.</p> <p><b>Note:</b> Connect equipment to these outlets using a standard molded 6 A plug.</p>
<p><b>2</b></p>	<p><b>Surge Protection outlet</b></p>	<p>This outlet helps to provides full time protection for connected equipment from power surges or spikes, when the Back-UPS is turned on or off.</p> <p>The <b>Surge Protection</b> outlet does not supply battery backup power to connected equipment. Connect a printer, scanner or other devices that do not require battery backup protection.</p> <p><b>Note:</b> Connect equipment to this outlet using a standard molded 6 A plug.</p>
<p><b>3</b></p>	<p><b>Utility Power cable</b></p>	<p>Use this cable to connect the Back-UPS to utility power.</p>
<p><b>4</b></p>	<p><b>Data port</b></p>	<p><b>For BE700Y-IND only.</b> To use PowerChute Personal Edition, connect a USB cable (supplied) to the data port.</p>
<p><b>5</b></p>	<p><b>Circuit Breaker</b></p>	<p>Press the circuit breaker reset button after an overload condition or a short circuit has occurred causing the circuit breaker to trip. This action can be taken when the Back-UPS is operating on utility or battery power.</p>

# Operation

## Turn on the Back-UPS

Press the **POWER ON** button located on the top of the Back-UPS. The **Power On** LED will illuminate and a single short beep will be audible to indicate that the Back-UPS is providing protection for the connected equipment.

The Back-UPS battery charges to capacity during the first 16 hours while connected to utility power. The Back-UPS battery will charge while the Back-UPS is turned on or off and is connected to utility power. Do not expect full battery runtime capability during the initial charge period.

## Status indicators

Status	LED Indicator	Audible Indicator On	Audible Indicator Terminates
<b>Power On</b> The Back-UPS is supplying utility power to connected equipment.	The LED illuminates green.	None	N/A
<b>On Battery</b> The Back-UPS is supplying battery power to battery backup outlets.	The LED illuminates amber. The LED is not illuminated during the beeps.	The Back-UPS beeps four times every 43 seconds.	Beeping stops when utility power is restored or the Back-UPS is turned off.
<b>Low Battery</b> The Back-UPS is supplying battery power to the battery backup outlets and the battery is near a total discharge state.	The LED flashes red.	The Back-UPS emits rapid beeping once every half second.	Beeping stops when utility power is restored or the Back-UPS is turned off.
<b>Replace Battery</b> <ul style="list-style-type: none"><li>• The battery is disconnected.</li><li>• The battery needs to be charged or replaced.</li></ul>	The LED flashes amber and green alternatively.	The Back-UPS emits short beeps once every two seconds	The Back-UPS is turned off.
<b>Sleep Mode</b> While operating on battery power the battery is discharged. The Back-UPS will awaken once utility power is restored.	None	The Back-UPS beeps once every four seconds.	<ul style="list-style-type: none"><li>• Utility power is restored.</li><li>• Utility power is not restored within 32 seconds.</li><li>• Back-UPS is turned off.</li></ul>

Status	LED Indicator	Audible Indicator On	Audible Indicator Terminates
<b>Overload Shutdown</b> While operating on battery power an overload condition has occurred in one or more of the battery backup outlets.	The LED illuminates red.	Constant tone	The Back-UPS is turned off.

## Voltage Sensitivity Adjustment

The Back-UPS detects and reacts to line voltage distortions by transferring to battery backup power to help protect connected equipment.

If the Back-UPS switches to battery power too frequently or too infrequently, adjust the transfer voltage and sensitivity settings:

1. Connect the Back-UPS to a utility power source. The Back-UPS will be in **Standby** mode. No LED will be illuminated.
2. Press and hold the POWER ON/OFF button until the LED flashes alternately green-red-amber. Release the button. The Back-UPS is now in **Program** mode.
3. The **Power On** LED will flash either green, amber, or red to indicate the voltage sensitivity level. Refer to the table for an explanation of the transfer voltage sensitivity levels.
4. To select **LOW** sensitivity, press the POWER ON/OFF button until the LED flashes green.
5. To select **MEDIUM** sensitivity, press the POWER ON/OFF button until the LED flashes amber.
6. To select **HIGH** sensitivity, press the POWER ON/OFF button until the LED flashes red.
7. To exit **Program** mode wait five seconds and all LED indicators will extinguish. **Program** mode is no longer active.

LED Flashes	Sensitivity Setting	Input Voltage Range for Utility Operation	Recommended Use
Green	LOW	167 Vac to 280 Vac	Use this setting with equipment that is less sensitive to fluctuations in voltage or waveform distortions.
Amber	MEDIUM (factory default)	170 Vac to 270 Vac	Use this setting for normal conditions. This setting is also used when power generator is the input power source.
Red	HIGH	176 Vac to 260 Vac	Use this setting when connected equipment is sensitive to voltage fluctuations or waveform distortions.

# Troubleshooting

<b>Problem</b>	<b>Possible Cause</b>	<b>Corrective Action</b>
The Back-UPS will not turn on	The POWER ON/OFF button has not been pushed.	Press the POWER ON/OFF button.
	The Back-UPS is not connected to utility power. There is no utility power available at the wall outlet. The utility power is experiencing a brownout or over voltage condition.	Make sure the power cable is securely connected to the wall outlet, and that there is utility power available at the wall outlet. Where applicable, check that the wall outlet is switched on.
	The utility input voltage is out of range.	Adjust the transfer voltage and sensitivity range.
Connected equipment loses power	While operating on battery power, an overload condition has occurred causing the Back-UPS to shut down.	Disconnect nonessential equipment from the Back-UPS. Press the POWER ON/OFF button. Reconnect equipment one device at a time. If the Back-UPS shuts down again, disconnect the device that caused the overload condition.
	An overload condition has occurred, when the Back-UPS is connected to the utility power, causing the circuit breaker to trip.	Reset the circuit breaker.
	The Back-UPS battery is discharged.	Connect the Back-UPS to utility power and allow the battery to recharge for 16 hours.
	The Back-UPS may require service.	Contact APC by Schneider Electric Customer Support for assistance.
The Back-UPS is operating on battery power while connected to utility power.	The Back-UPS is not securely connected to a utility wall outlet. There is no utility power available at the wall outlet.	Verify that the Back-UPS is connected to a utility wall outlet. Verify that there is utility power available at the wall outlet.
	The utility input voltage is out of range.	Adjust the transfer voltage and sensitivity range.

Problem	Possible Cause	Corrective Action
The Back-UPS does not provide adequate battery runtime.	The battery is not charged to capacity.	Disconnect the equipment connected to the UPS. Allow the UPS to charge for 16 hours. The battery should charge to full capacity during this time.
	The battery life cycle is near completion.	As the battery ages the runtime capability decreases. Contact APC by Schneider Electric Customer Support for assistance.

## Specifications

		BE700Y-IND	BE800-IND
<b>Input</b>	Voltage	167 Vac to 280 Vac	
	Frequency	50 Hz $\pm$ 10%	
	Brownout transfer	167 Vac typical (low sensitivity)	
	Over voltage transfer	270 Vac typical	
<b>Output</b>	<b>Battery Backup + Surge Protection</b> outlets	700 VA, 420 W	800 VA, 480 W
	<b>Surge Protection</b> outlet	230 Vac $\pm$ 8%	
	Voltage	On battery power 230 Vac $\pm$ 5%, (modified sine wave) on utility power 190 Vac to 250 Vac	
	Frequency - On Battery	50/60 Hz $\pm$ 1%	
	Transfer time	5 ms typical, 10 ms maximum	
<b>Communication</b>	<b>For BE700Y-IND only.</b> Back-UPS data port to USB on computer		
<b>Protection and Filtering</b>	Utility power surge protection	Full time, 150 joules	
	EMI/RFI filter	Full time	
	Utility input	User resettable circuit breaker	
<b>Battery</b>	Type (maintenance-free)	12 V, 9 Ah	12 V, 12 Ah
<b>Physical</b>	Net weight	7.2 kg	9 kg
	Dimensions H x W x D	13 cm x 22 cm x 29 cm (5 in x 9 in x 11 in)	
	Operating temperature	0° C to 40° C (32° F to 104° F)	
	Storage temperature	-15° C to 45° C (5° F to 113° F)	
	Operating relative humidity	0 to 95% non condensing	
	Operating elevation	0 m to 3000 m (0 ft to 10000 ft)	
<b>Replacement Battery Cartridge</b>		RBC17	RBC4
To order replacement battery cartridge contact APC by Schneider Electric Customer Support. Always recycle used batteries.			

# PowerChute™ Personal Edition Software for BE700Y-IND only

## Overview

PowerChute Personal Edition Software allows you to use your computer to access additional power protection and management features of the Back-UPS.

Using PowerChute, you can:

- Preserve work in progress during a power outage by putting your computer into Hibernate mode. When the power returns, the computer will appear exactly as it did before the power outage.
- Configure the Back-UPS management features, such as power-saving outlets, shutdown parameters, audible alarms, and more.
- Monitor and view the status of the Back-UPS, including the estimated runtime, power consumption, power event history, and more.

Available features will vary by Back-UPS model and operating system.

If you choose not to install PowerChute, the Back-UPS will still provide backup power and power protection to connected equipment. However, you will only be able to configure a limited number of features using the display interface.

## Compatibility

PowerChute is compatible with Windows operating systems only. For a detailed list of supported operating systems, go to [www.apc.com](http://www.apc.com), select **Software & Firmware**.

For Mac operating systems, we recommend using the native shutdown application (within System Preferences) which recognizes your battery backup and allows you to configure shutdown of your system during power outages. To access this application, connect a USB cable from the Back-UPS DATA PORT (POWERCHUTE PORT) to a USB port on your computer, and see the documentation provided with your computer.

## Installation

To install PowerChute Personal Edition (PCPE) software, connect the supplied USB cable between the data port on the UPS and to a computer with access to the web.

On the computer, go to [www.apc.com/tools/download](http://www.apc.com/tools/download). Select **Software Upgrades - PowerChute Personal Edition** in the **Filter by Software/Firmware** drop down menu. Select the appropriate operating system. Follow directions to download the software.

## Service

If the unit requires service, do not return it to the dealer. Follow these steps:

1. Review the *Troubleshooting* section of the manual to eliminate common problems.
2. If the problem persists, contact APC by Schneider Electric Customer Support.
  - a. Note the model number and serial number and the date of purchase. The model and serial numbers are located on the rear panel of the unit and are available through the LCD display on select models.
  - b. Call APC by Schneider Electric Customer Support and a technician will attempt to solve the problem over the phone. If this is not possible, the technician will issue a Service Request Number.
  - c. If the unit is under warranty, the repairs are free.
3. An Authorised Service Representative will visit your location and try to resolve the issue.

## APC by Schneider Electric Customer Support India

<b>Internet</b>	<a href="http://www.apc.com/support">http://www.apc.com/support</a>
<b>Toll Free BSNL network</b>	1 800 425 4272
<b>All other networks</b>	city code + 39022272
<b>E-mail</b>	<a href="mailto:indiainfo@apc.com">indiainfo@apc.com</a>